

KICKASS



CONTROL HUB WITH 40A DCDC CHARGER WITH BLUETOOTH

OWNER'S MANUAL

KACTRLHB40DCDCBT

V1.1

SAFETY INFORMATION

Read this manual carefully before using this device. Failure to follow these safety precautions may result in electric shock, fire, or injury. Keep this manual for future reference.

Warnings

- Do not operate the control hub with the lid open while connected to a battery.
- All 12V electrical installation work should be carried out by a qualified professional. Incorrect installation may cause damage to the unit, vehicle, or connected equipment.
- Do not exceed the maximum current ratings of any input or output, including Anderson connectors, switches, USB ports, and cigarette sockets.
- Do not allow loose metal objects, tools, or conductive materials to enter the control hub, ports, or fuse area.
- Do not expose the control hub to excessive moisture, water ingress, or heavy dust.
- Do not connect charging sources that exceed the specified voltage ranges.
- Do not operate an external battery charger through the Anderson connectors while the DCDC charger is active.
- Ensure correct polarity when connecting batteries, alternator input, solar input, and accessories. Incorrect polarity may cause permanent damage.
- Do not modify internal wiring, protection devices, or fuse ratings beyond specified limits, as this may lead to failure or fire risk.

Safety Notes

- Ensure the control hub is securely mounted before use and that all mounting fasteners are properly tightened.
- Use appropriately rated cable sizes suitable for the expected current and cable length to avoid voltage drop or overheating.
- Ensure adequate ventilation around the control hub to prevent heat buildup during operation.
- Check that all screws, terminals, and internal connections are secure before connecting power.
- Disconnect the battery before performing any wiring, installation, or maintenance work.
- Only use fuses of the correct type and rating when replacing blown fuses.
- The built-in voltmeter and low-voltage alarm are intended as a guide only; always refer to battery manufacturer specifications for accurate state-of-charge information.
- Ensure solar panels connected to the DC-DC charger do not exceed the specified open-circuit voltage range.
- Regularly inspect cables, terminals, and connectors for signs of wear, corrosion, or damage and replace if necessary.

TABLE OF CONTENTS

SAFETY INFORMATION	2
PRODUCT SPECIFICATIONS	4
INCLUDED COMPONENTS	5
PRODUCT FEATURES	6
PRODUCT OVERVIEW	7
PRODUCT INSTALLATION	9
MOUNTING INSTRUCTIONS	9
WIRING IN SWITCHES	11
CONNECTING TO BATTERY	13
CONNECTING THE DCDC CHARGER	16
CONNECTING THE SOLAR INPUT	17
ROTATING THE DCDC CHARGER	18
USING WITH LITHIUM REMOTE DISPLAY UNIT	21
WIRING DIAGRAM	23
SWITCH LIGHTING	24
PRODUCT CONFIGURATION	25
USING THE CONTROL HUB	27
VOLTMETER	27
LED LIGHT	27
INPUTS/OUTPUTS	28
IN/OUT ANDERSON-STYLE PLUGS	28
SWITCHES	29
FUSE BOX	29
OUTPUTS	30
USBS	30
CIGARETTE SOCKETS	30
BLUETOOTH APP CONNECTION AND OPERATION	31
TROUBLESHOOTING	34
WARRANTY & SUPPORT INFORMATION	35

PRODUCT SPECIFICATIONS

PRODUCT DIMENSIONS	400 x 305 x 110mm (LWH)
PRODUCT WEIGHT	5.6kg
MATERIAL	Powder-coated aluminium
VOLTAGE	12V
CIGARETTE SOCKET OUTPUT	2 x 10A max each
USB OUTPUT	2 x USB-A 12W 1 x USB-C 45W 1 x QC3.0 18W
ANDERSON INPUT/OUTPUT	4 x 50A (shared fuse)
THREE-PIN ANDERSON INPUT	For alternator and ignition wiring
TWO-PIN ANDERSON INPUT (BLACK)	For unregulated solar panel
ROCKER SWITCH	5 x 20A max each
DCDC CHARGER INFORMATION	
DCDC CHARGER	40A DCDC Charger with Solar MPPT
INPUT VOLTAGE	12 or 24V
ALTERNATOR INPUT VOLTAGE RANGE	9-32V DC
SOLAR INPUT VOLTAGE RANGE	9-32V DC
MAXIMUM INPUT CURRENT	56A
MAXIMUM CONTINUOUS CHARGING CURRENT	40A
MAXIMUM OUTPUT POWER	500W
RECOMMENDED OUTPUT FUSE SIZE	50A
STANDBY CURRENT	<10mA
EFFICIENCY	Approximately 93% at full load
AMBIENT OPERATING TEMPERATURE	20°C to 80°C
OTHER INFORMATION	
RECOMMENDED BATTERY CAPACITY	
LEAD ACID (AGM, GEL, WET, CAL)	160Ah to 500Ah
LiFePO₄ (LITHIUM)	50Ah to 500Ah

DCDC Charger User Manual:

[KickAss Smart 12V/24V 40A DCDC Charger](#)

INCLUDED COMPONENTS



1 x Control Hub with 40A DCDC Charger



2 x 1-metre cable (red and black)



Stickers

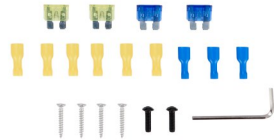

Fuses

PRODUCT FEATURES

- The integrated 40A DCDC charger simplifies dual battery system installation.
- Power up to 15 devices simultaneously from a single control hub.
- Monitor and configure the charger remotely using Bluetooth on your smartphone.
- Charge your auxiliary battery directly from the vehicle alternator or solar.
- Internal circuit protection safeguards your system with fuses and auto-reset breakers.
- Five backlit 20A rocker switches control multiple accessories easily.
- Two 15A cigarette sockets provide reliable power for high-draw devices.
- Two QC3.0 USB ports and two USB-C PD ports support fast charging.
- Four Anderson outputs deliver 50A shared power.
- Compatible with both 12V and 24V alternators for versatile vehicle setups.
- Adjustable maximum input current makes the charger suitable for hybrid vehicles.
- Automatic lithium battery recovery restores flat batteries without user intervention.
- Integrated LED light ensures visibility during night-time or low-light conditions.
- Pre-drilled holes allow easy mounting of the Lithium Battery Remote Display.

PRODUCT OVERVIEW

FRONT VIEW

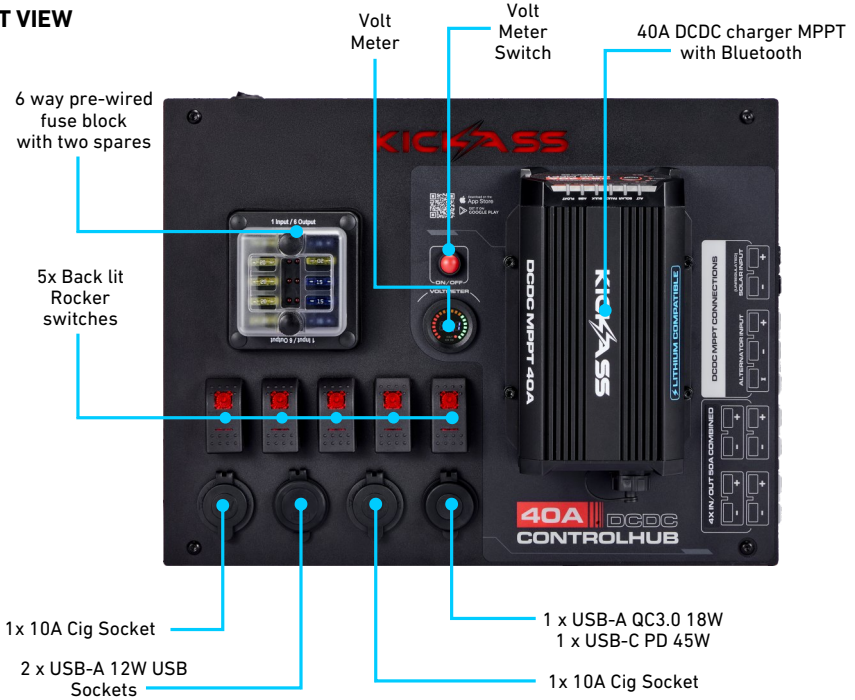

SIDE VIEW

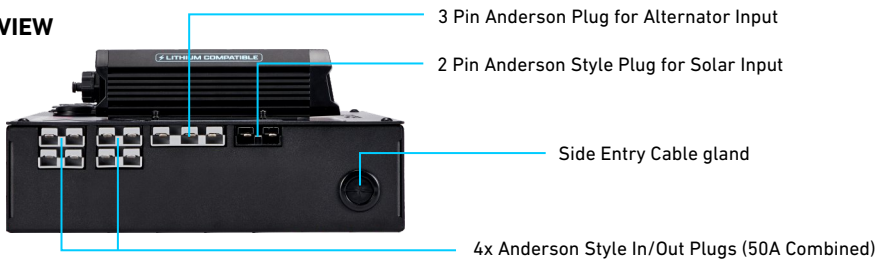

TOP VIEW





1. Status Indicators

- ALT - Alternator Indicator
- SOLAR - Solar Panel Indicator
- FAULT - Fault Indicator
- BULK - Bulk Stage Indicator
- ABS - Absorption Stage Indicator
- FLOAT - Float Stage Indicator

2. Battery Mode Indicator

3. Mode Button

PRODUCT INSTALLATION

MOUNTING INSTRUCTIONS

What You Will Need

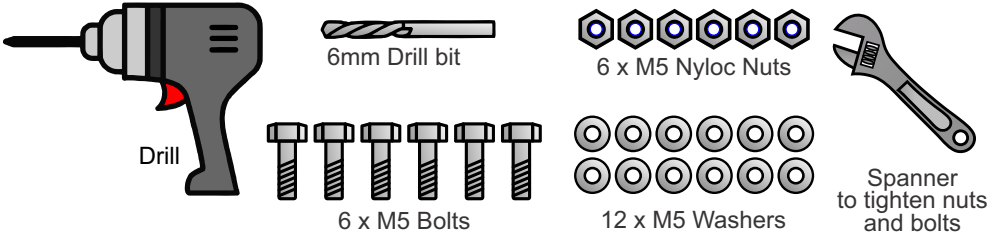

Step 1: Using the supplied Allen key, remove the four screws and open the control hub.



Step 2: Ensure all wiring is connected and there are no internal terminals or studs loose.



Step 3: Decide where in your vehicle where you will be mounting your Control Hub. Using the Control Hub as a guide, mark the 6 holes on your mounting surface. Lift the control hub into place to ensure these marks align with the 6 pre drilled holes in the control hub.

Step 4: Using a 6mm drill bit, drill through the 6 pre-marked holes on your mounting surface. *Note:* if mounting on a metal surface you may need to use a smaller pilot hole or step drill.

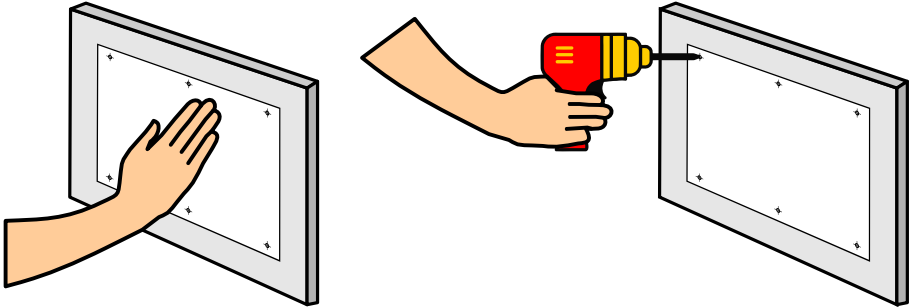

Step 5: Lift the control hub into position and insert the 6 bolts and washers into the pre-drilled holes. Secure with a nut and washer on the rear. Tighten with a spanner until secure.

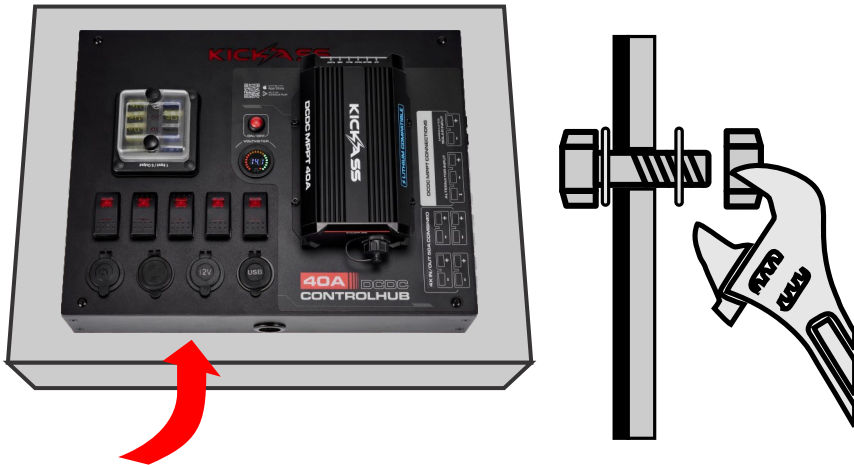

WIRING IN SWITCHES

The unit comes fully assembled and ready to use. The following instructions are for wiring in the 5 switches and connecting the unit to your battery.

What You Will Need

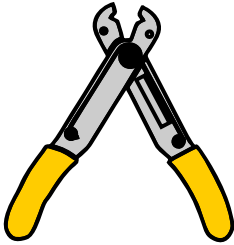

Wire Crimper

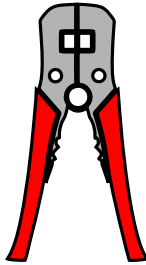

Wire Stripper

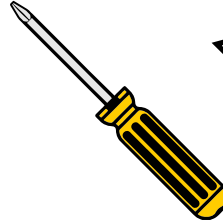

Phillips Head
Screwdriver

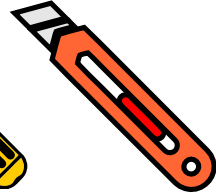

Utility Knife

Note: Ensure the unit is disconnected from the battery prior to attempting any wiring

Step 1: Using the supplied allen key, remove the 4 screws and open the Control Hub

Step 2: For wiring in switches, select the appropriate sized spade and ring terminal for your accessories wiring.

Note: The yellow terminals are recommended for use with 10-12AWG wire and the blue terminals are recommended for use with 12-14AWG wire.

Step 3: Using a knife, cut the grommets on the side or bottom of the unit that your accessory wires will run through. Push approximately 30cm of your accessories wiring through the grommet

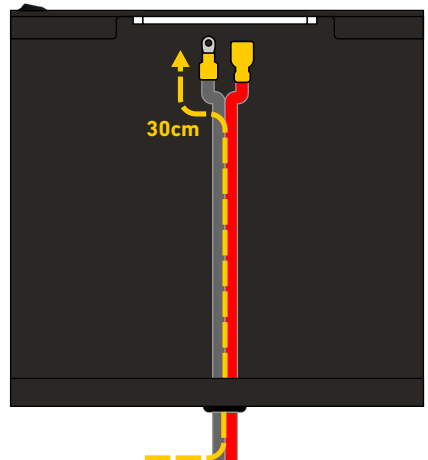

Step 4: If your wiring is dual core, separate approximately 30cm of the two wires.

Note: You may need to remove the 30cm of the outer layer of insulation if your wire is double insulated

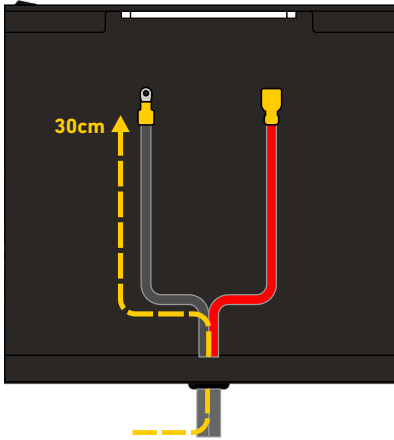

Step 5: Strip approx 1cm of insulation from each cable using a wire stripper, select and crimp the appropriate sized spade terminal to your positive wire and the ring terminal to the negative wire.

Note: Check with the manufacturer of your accessory to determine which wire is positive and which is negative crimping terminals.

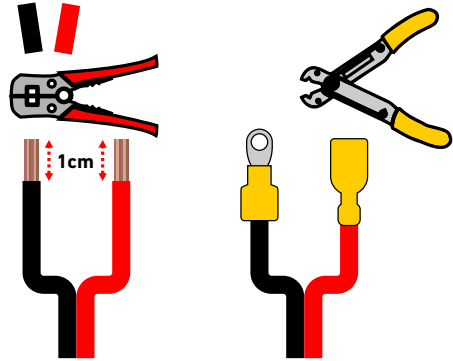

Step 6: Connect the spade terminal to the bottom blank tab on your switch and using a Phillips head screwdriver, connect the negative ring terminal to one of the spare screw positions on the negative bus bar.

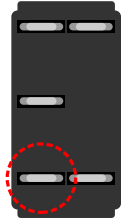

Configuration 1 (From Factory):



SWITCH
TURNED OFF



SWITCH
TURNED ON

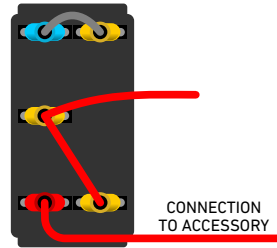

WIRING DIAGRAM

Step 7: Tuck cables neatly under the control hub and carefully close the lid, returning the 4 screws to secure the control hub down.



CONNECTING TO BATTERY

What You Will Need



Utility Knife



Adjustable Spanner

Step 1: Using the supplied Allen key, remove the four screws and open the control hub.



Step 2: Using a knife, cut the grommets on the side or bottom of the unit that your battery wires will run through. Push approximately 30cm of the included battery wire through the grommet.

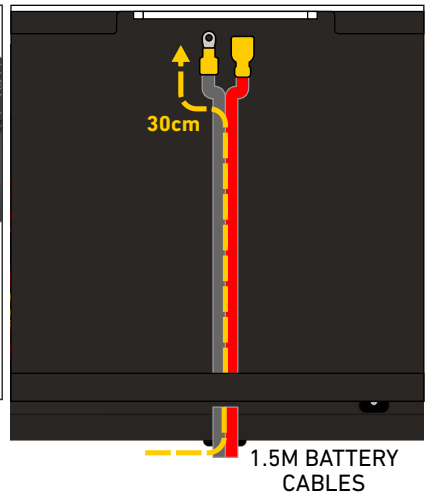

Step 3: Using the spanner, remove the bolt and washer off both the positive (red) and negative (black) terminal posts on the rear of the control hub.

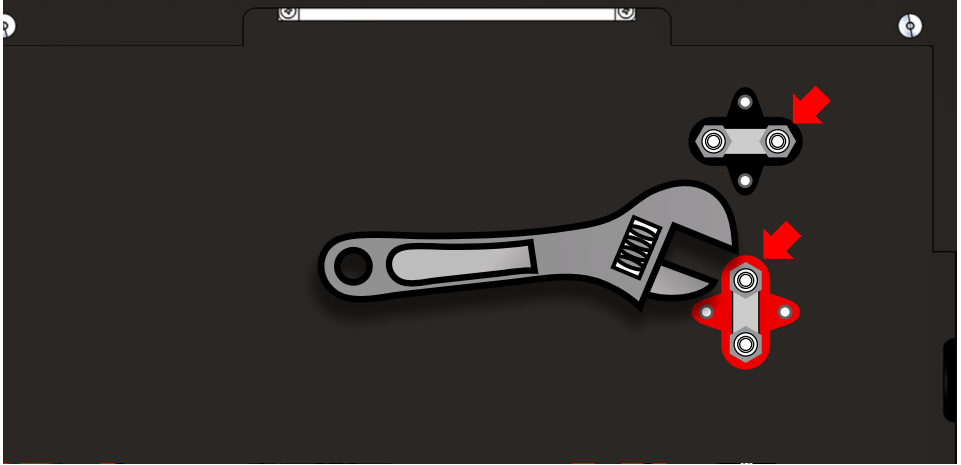

Step 4: Attach the wire with the black terminal cover to the negative (black) terminal post and the wire with the red terminal cover to the positive (red) terminal. Replace the nut and washer and retighten with a spanner.

Note: Ensure the wires are not connected to the battery.

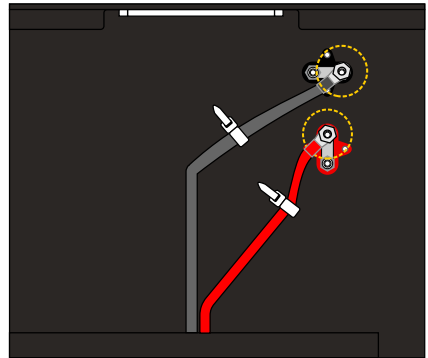

Step 5: Tuck cables neatly under the control hub and carefully close the lid, returning the 4 screws to secure the control hub down.



Step 6: Connect the other end of the wires to the battery by first attaching the wire with the red terminal cover to the positive (red) terminal on your battery, and then attaching the wire with the black terminal cover to the negative (black) terminal on your battery.



CONNECTING THE DCDC CHARGER

The KickAss Control Hub includes a built-in DCDC Charger suitable for charging from a vehicle alternator. The easiest way to connect the control hub to your vehicle is by using the [KickAss Heavy Duty Plug and Play DCDC Wiring Kit](#) (sold separately).

The triple Anderson style connector fitted to the control hub interfaces with the KickAss Plug & Play Wiring Kit, providing a simple, quick release vehicle charging solution. This triple connector and cable provide alternator power to the DCDC charger on the control hub, along with an ignition source for charging in vehicles that are fitted with Smart or Temperature Compensating Alternators.

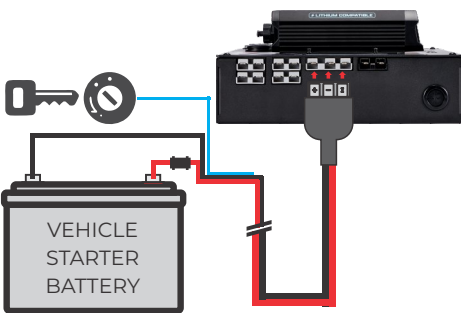
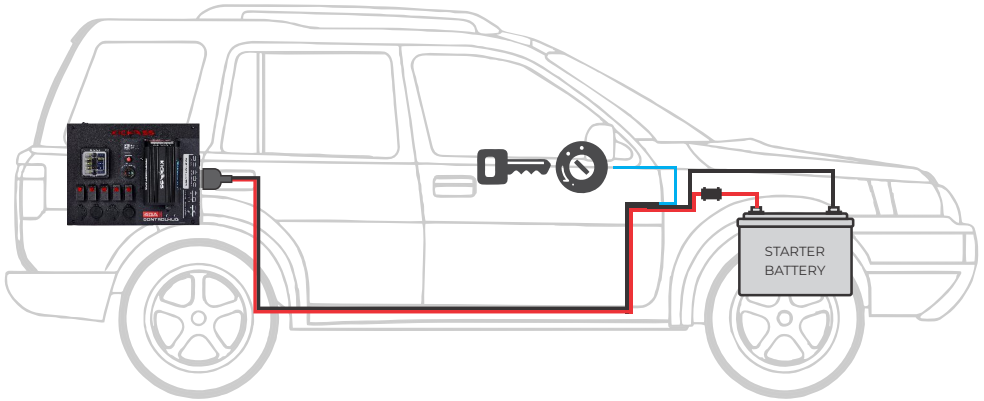

KickAss Heavy Duty Plug and Play
DCDC Wiring Kit - 6.5m
SKU: KAHDBWKP65

CONNECTING THE SOLAR INPUT

The KickAss Control Hub includes a built-in DCDC Charger with an MPPT regulator suitable for charging from unregulated solar panels. To connect your solar panel to the regulator simply plug it in via the black Anderson plug on your control hub.

Note:

- Your solar panel open circuit voltage must not exceed 32 Voc, this can generally be found on the sticker on the rear of your solar panel.
- If your solar panel is fitted with a built-in regulator, you will need to bypass the regulator port. Alternatively you can connect your regulated solar panel to any of the in/out Anderson-style connectors.

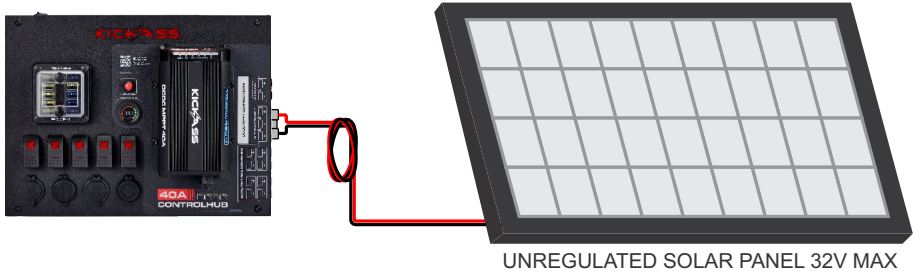

ROTATING THE DCDC CHARGER

The KickAss Control Hub has been designed to allow the DCDC charger to be rotated.

What You Will Need



Flat Head
Screwdriver



Phillips Head
Screwdriver



Adjustable
Spanner

Note:

- Ensure the unit is disconnected from the battery prior to attempting any wiring.
- It is recommended to take a photo prior to removing wires to ensure all wires are put back in the correct position.

Step 1: Using the supplied Allen key, remove the 4 screws and open the Control Hub.

Step 2: Remove the wires from the solar (Green and Black) and alternator (Red, Black and Blue) Anderson-style plugs. Note: Do not pull too hard on the wire as this may damage the unit.



Insert a flat head screwdriver into the front of the Anderson style plug



Push down the spring clip below the lug pin to release

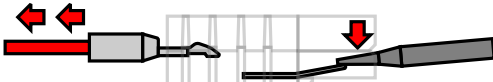

Apply a light pulling force on the wire

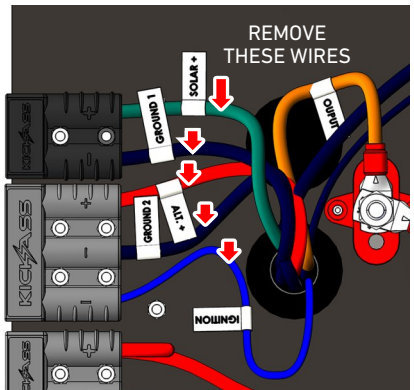

Step 3: Unbolt the DCDC output wires (one brown and two black) from the positive (red) and negative (black) terminal post.

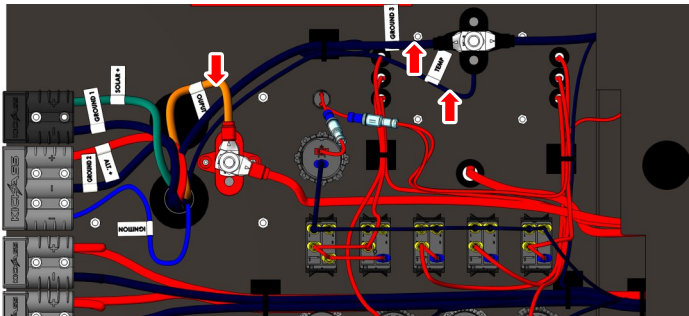

Step 4: Using the Phillips head screwdriver and adjustable spanner, undo the four bolts securing the DCDC charger to the Control Hub.

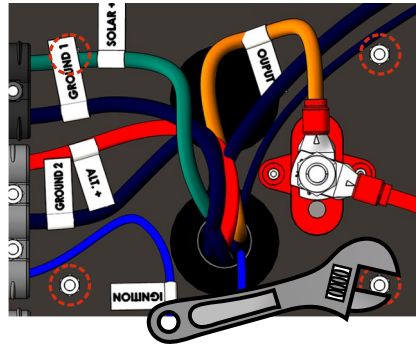

Step 5: Carefully remove the DCDC charger from the Control Hub ensuring all wires come out freely. Note: Do not force the unit as you remove it, as this may cause damage.



Step 6: Rotate the DCDC Charger and carefully thread the wires through the other large hole located under the DCDC charger's mounting location. Align the mounting holes on the charger with the holes on the Control Hub and replace the mounting bolts, ensuring they are adequately tightened.



Step 7: Replace the wires from the solar (Green and Black) and alternator (Red, Black and Blue) Anderson-style plugs. This can be done by gently pushing the Anderson pin into the plug.

Note: Do not forcibly pull the wire as this may damage the unit.

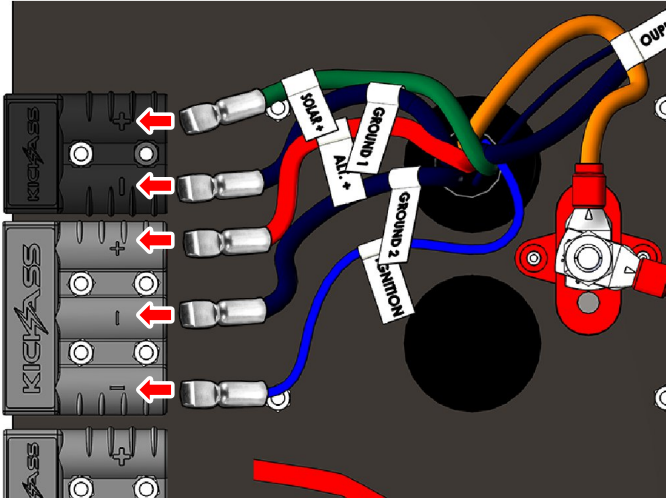

Step 8: Tuck the cables neatly under the Control Hub and carefully close the lid, returning the 4 screws to secure the Control Hub down.



USING WITH LITHIUM REMOTE DISPLAY UNIT

The Control Hub is designed to work with our KickAss range of lithium batteries. Underneath the sticker, holes have been cut in the face panel to allow you to mount the RDU on the control hub without any drilling.

What You Will Need



KickAss Lithium Battery



RDU and RJ45 Cable

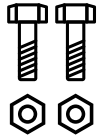

2x M4 Nuts and Bolts

Note: Ensure the unit is disconnected from the battery prior to attempting any wiring.

Step 1: Using the supplied Allen key, remove the 4 screws and open the Control Hub.

Step 2: Locating the 2 holes on the rear side of the face panel, cut away the sticker using a sharp knife. Ensure all wiring is clear of the area and positioned safely to avoid accidental damage during cutting.

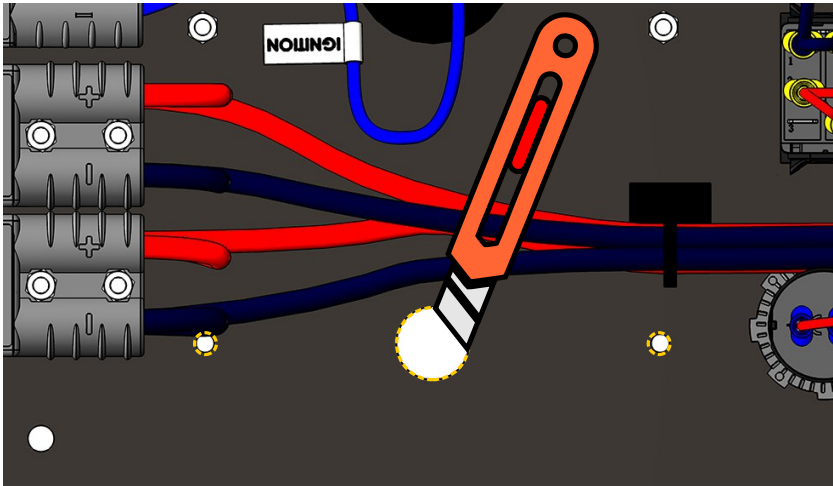

Step 3: Mount the RDU housing on your desired place and secure using nuts and bolts.



Step 4: Using the extension cable, connect your RDU to your KickAss Lithium Battery.



WIRING DIAGRAM

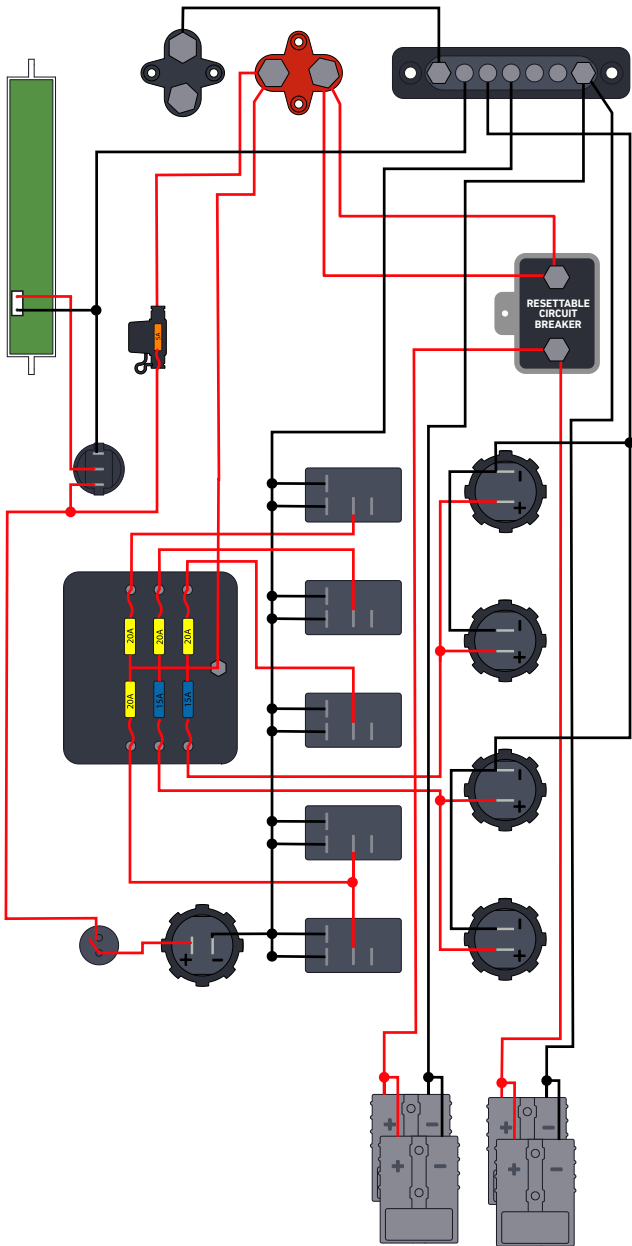

SWITCH LIGHTING

The Control Hub switches can be wired in three different ways that will change the lighting configuration. Below are the configurations and switch wiring diagrams which can be setup as specified below.

Configuration 1 (From Factory):



SWITCH
TURNED OFF



SWITCH
TURNED ON

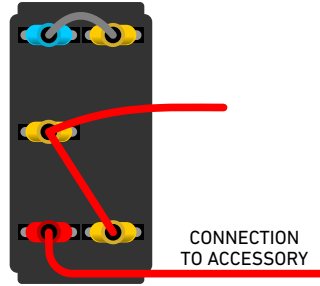

WIRING DIAGRAM

CONNECTION
TO ACCESSORY

Configuration 2:



SWITCH
TURNED OFF



SWITCH
TURNED ON

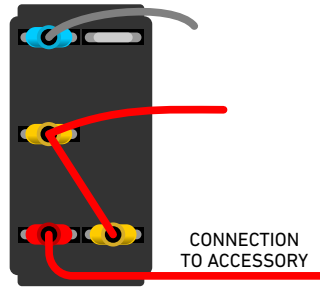

WIRING DIAGRAM

CONNECTION
TO ACCESSORY

Configuration 3:



SWITCH
TURNED OFF



SWITCH
TURNED ON

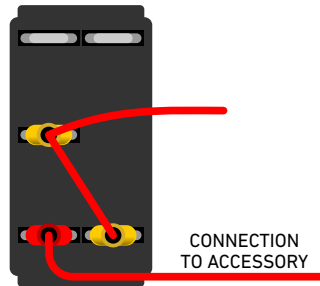

WIRING DIAGRAM

CONNECTION
TO ACCESSORY

PRODUCT CONFIGURATION

Check whether the DCDC charger's battery type is set to LifePO4. If it is not, please follow these steps:

Setting the Battery Type – via Mode Switch

1. Press and hold the MODE button for four seconds.
2. The selected mode will flash indicating that the charger has entered battery selection mode.
3. Press the mode button repeatedly to cycle through the available battery types:
AGM ▶ Cal (Calcium-based) ▶ LiFePO4 (Lithium) ▶ Gel ▶ Wet
4. Stop on the desired battery type; it will be saved automatically after a short pause.

Setting the Battery Type – via Bluetooth App

1. Download the mobile application from the Apple App Store or Google Play Store.



KA CHARGE 4.4
Kickass Products Pvt Ltd
Designed for iPhone
Free

2. When the Bluetooth mobile application first connects to the DCDC charger, it will automatically check for any available firmware updates. If an update is available, it must be downloaded and installed before the app can be used.

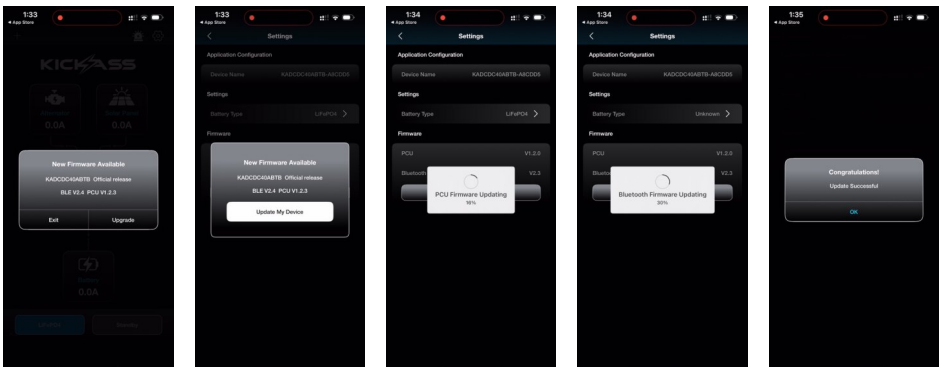

During the Over-The-Air (OTA) update process, all LED status lights on the DCDC charger will flash.



Important: Do not disconnect power to the DCDC charger or close the app while the OTA update is in progress.

3. Configure the battery type by tapping the Settings icon on the main page of the app. Select Battery Type and select LiFePO4

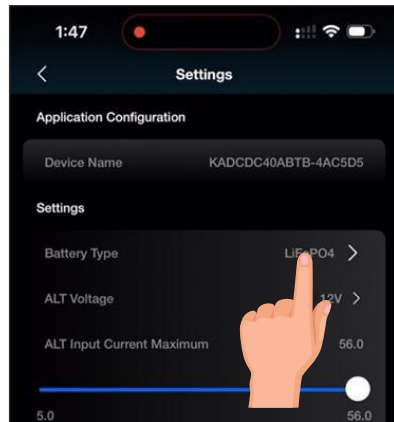
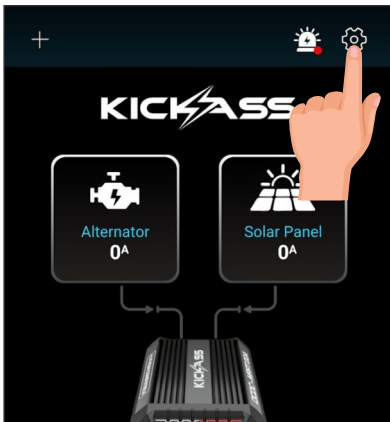

USING THE CONTROL HUB

Voltmeter

The inbuilt voltmeter will display the voltage of your battery, this can be turned on and off using the little red switch on the unit. For an accurate voltage reading, disconnect all loads and charging sources from the control hub and test. The voltmeter is equipped with an audible low battery alarm that activates when the voltage is below 11.0V. To mute this alarm, simply turn the voltmeter off or connect a charging source.

Note: The battery voltage table on the sticker of the Control Hub is to be used as a guide for AGM batteries' SOC % only, check your battery specifications for accuracy.



LED Light

The Control Hub is fitted with an LED light. This can be turned on and off using the switch on the top of the unit. A red LED indicator will be visible on the switch when powered on.



INPUTS/OUTPUTS

4x IN/OUT (50A Combined) Anderson-Style Plugs

- Input/Output power supply - Compatible connection to a charger or load.
- The single bank of 4 x Anderson-style plugs is protected by a 50A circuit breaker.
- All Anderson style plugs must not exceed a maximum of 50A current.



WARNING:

1. Please check product specifications if connecting multiple charging sources.
2. Do not use an external charger while the DCDC Charger is operating.
3. Exceeding 50A combined current rating will trip the 50A auto reset circuit breaker.

Switches

5 x 20A Backlit Rocker Switches

- Easy DIY install to hard wire all your camp accessories.
- Included stickers to identify the purpose of the switch.
- Each switch is fused with a 20A Fuse.

Note: Switches 1 and 2 share a 20A fuse so should only be wired with a maximum combined current of 20A.



WARNING:

Please consider the wiring size used when fitting your accessories. Wiring installed to power lower rated loads may require the existing fuse to be replaced with a smaller sized fuse.

Fuse Box

6 x Fuse Box with Two Spares

- Pre-wired for simplicity
- Two spares included
- Blown fuse detector.



OUTPUTS

USBs

- 2 x 2.4A high-powered USB-A 12W (White)
- 1 x quick charge 3.0 USB-A 18W (Blue)
- 1 x USB-C PD 45W

Cigarette Sockets

- 2 x cigarette socket output – maximum of 10A per socket



BLUETOOTH APP CONNECTION AND OPERATION

1. When the app is first launched, select your battery configuration (single or parallel). The series configuration is not applicable when the battery is configured for the Control Hub. To scan for a new battery, select the scan option at the top of the screen.

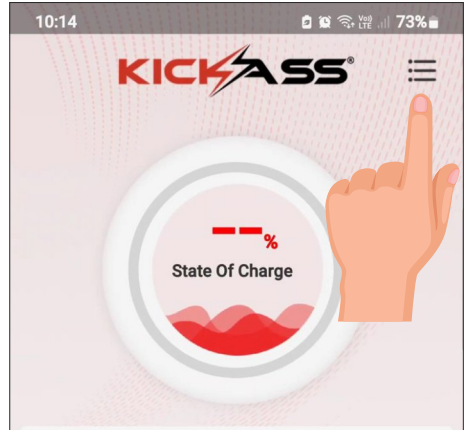
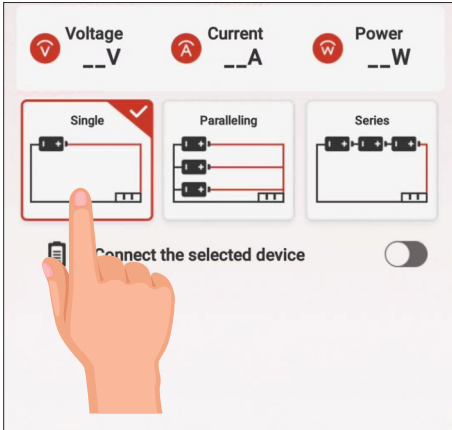

2. To select your battery, click the red icon next to the battery serial number. You can find the serial number printed on the back of your battery. Once the battery has been selected, the red icon will turn grey. Select the back button at the top of the page to return to the main battery summary page.

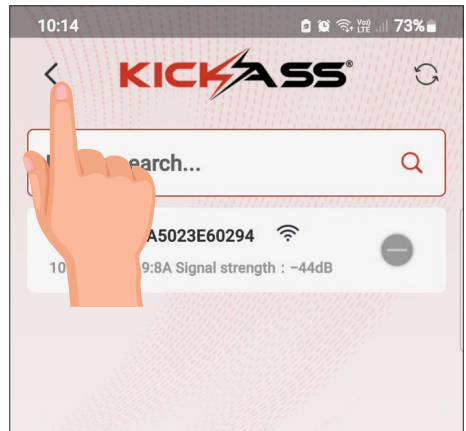
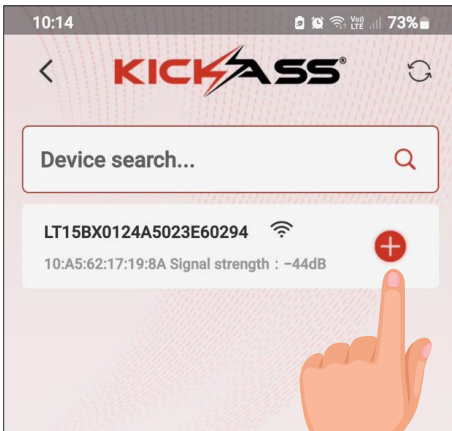

3. The state of charge (SOC), battery voltage, current and average power are shown on the main battery summary page. For detailed information about the battery, click on the battery serial number. The detailed battery information page shows state of charge (SOC), battery voltage, current, average power, status (standby, discharging, charging), battery temperature, time to full and time to empty.

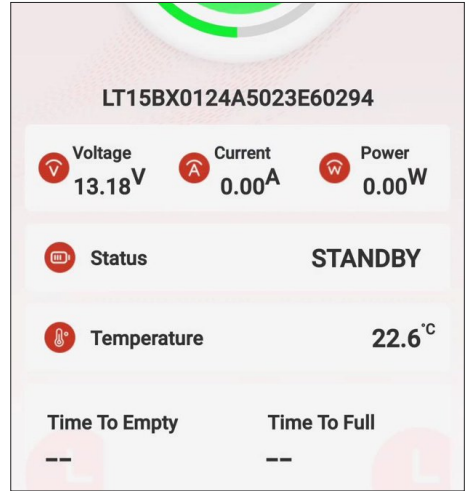
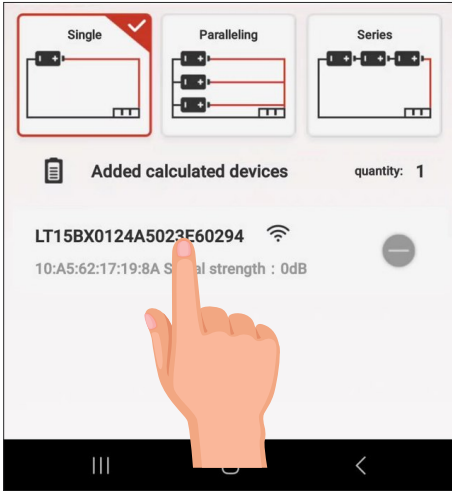

4. For system warning information and to change the temperature units, press the settings icon. Active system warnings will be shown on this page. Select the red arrow for further information. Select the preferred temperature units for display.

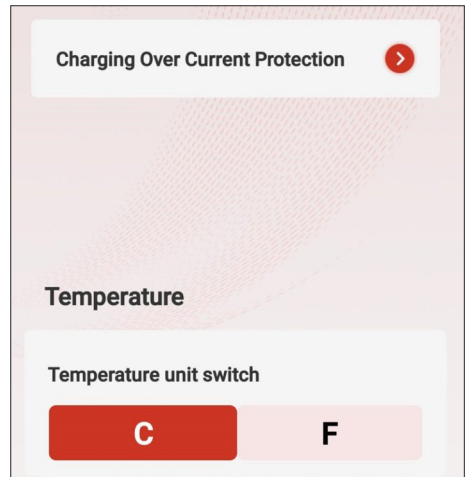
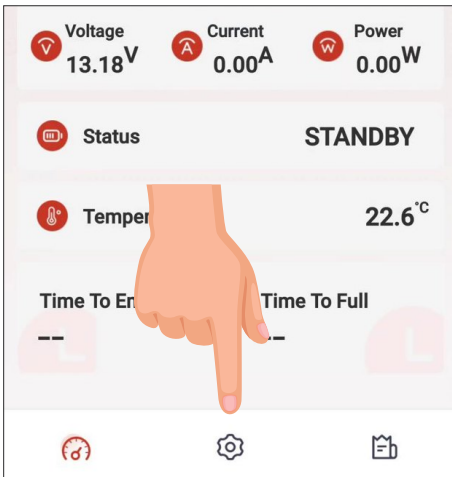

5. Example of further information of a system warning. Select the configuration button battery performance information.

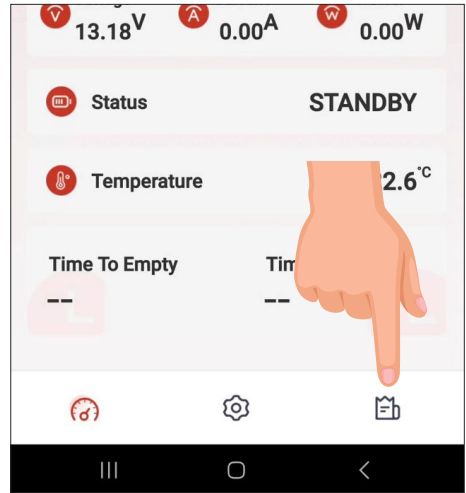
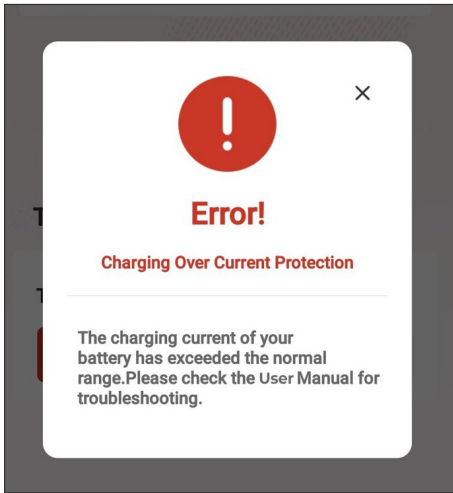

6. The battery performance page shows the battery health, the serial number / name, rated capacity, cycle count and cell voltage information. After disconnecting from the battery, the battery can be reselected from the quick start list on the main page of the app. To reconnect to the battery, press the red plus symbol.

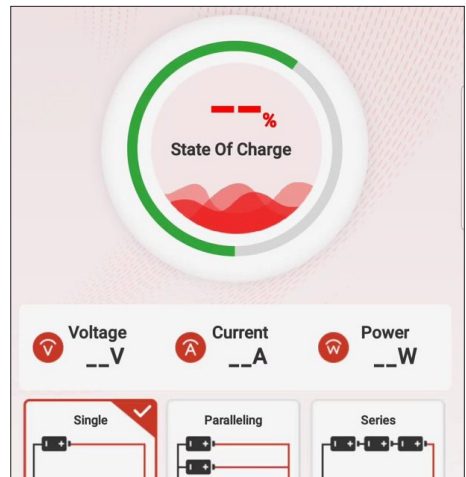
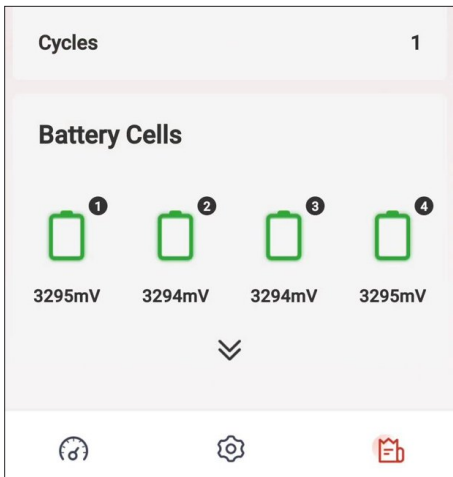

TROUBLESHOOTING

CONDITION	RECOMMENDED ACTION
The devices connected through the rocker switch won't turn on	<ul style="list-style-type: none">• Check the voltage from the voltmeter. If the LED indicator light is not illuminated, the battery is fully discharged. Please recharge the battery.• Please check for blown fuse, replace if needed.• Consider the right fuse to be used for your device. Using undersized fuses will cause continued blow fuses.
Anderson socket and/or cigarette sockets suddenly stopped working	<ul style="list-style-type: none">• Check that the combined load for the four Anderson sockets does not exceed 50A, or the cigarette sockets at 10A each. The sockets will reset automatically once the excess current is removed.• Inspect the connected devices and cables for faults or excessive current draw.• Ensure connectors are fully seated and free of debris.
Battery is not charging while using a device even when the battery box is charged	<ul style="list-style-type: none">• Monitor the battery voltage using the voltmeter. If the voltage is decreasing over time instead of increasing, the load connected is higher than the load being charged. Disconnect device/s that is not being used.• If using a solar panel for charging, make sure that the panels are well exposed to sunlight and properly shaded to maximise the capacity.• Check all input cables are properly connected and undamaged.

WARRANTY & SUPPORT INFORMATION

KICKASS LIMITED WARRANTY

Your KickAss product is backed by our limited warranty against defects in materials and workmanship for the applicable warranty period. Warranty periods vary by product - please check the product page or the KickAss Warranty Index for details.

If a fault covered by warranty occurs, KickAss will, at its discretion:

- Repair the product, or
- Replace the product with the same or equivalent model, or
- Provide another suitable remedy in line with Australian Consumer Law (ACL).

Warranty claims may be declined if the issue is caused by:

- Normal wear and tear.
- Improper use, faulty installation, or lack of maintenance.
- Modifications, tampering, or unauthorised repairs.
- Accidents, damage in transit (customer organised), or environmental causes.
- Consumable items, unless defective in materials or workmanship.
- Damage caused by external events such as severe weather (including storms, lightning, hail, or flooding), fire, impact, explosions, vandalism, or theft.

MAKING A WARRANTY CLAIM

1. Visit our Support Portal: supportportal.kickassproducts.com.au
2. Locate your product via the Products & Troubleshooting section.
3. Submit a claim through the product form and follow the guidance from our Customer Service Team.

All warranty claims must include a completed product form, proof of purchase, and clear evidence of the defect or fault. Incomplete submissions or missing information may cause delays in processing and could result in your claim being declined.

Costs from third-party inspections or repairs are not covered unless approved in writing by KickAss.

YOUR RIGHTS UNDER ACL

This warranty is provided in addition to your rights under the Australian Consumer Law. You may be entitled to a replacement or refund for major failures, and to compensation for other reasonably foreseeable loss or damage.

Need Help?

Product Support: support@kickassproducts.com.au

Warranty Claims: warranty@kickassproducts.com.au

Customer Support Portal: supportportal.kickassproducts.com.au

KICKASS

KickAss is a registered trademark of
KickAss Products Pty Ltd.

Designed & imported by
KickAss Products Pty Ltd
39 Iris Place, Acacia Ridge, QLD 4110
Australia

Made in China

