

# KICKASS



**12V TO 240V INVERTER  
PURE SINE WAVE RANGE**

**OWNER'S MANUAL**

KAPSWI2000 | KAPSWI3000 | KAPSWDSPY

V1.6

Thank you for selecting the KickAss Products pure sine wave inverter range. Our inverters deliver a clean and stable sine wave output, mirroring the quality of the 240V AC power outlet in your wall at home. This feature enables you to safely power sensitive electronic devices like laptops and various AC-powered appliances no matter where you are. Additionally, our pure sine wave inverter includes a 5V USB power output, providing versatility to power or charge numerous devices requiring 5V USB power.

## IMPORTANT SAFETY INFORMATION

To ensure safe operation and optimal performance, it is very important that you install and operate your KickAss Inverter correctly. Please read all instructions and guidelines in this User Manual, and ensure that you understand and follow them closely. KickAss Products strongly advises having all wiring and installation completed by a certified technician or licensed electrician to ensure compliance with all relevant electrical wiring regulations and installation codes. Failure to comply with these instructions may lead to damage to the unit and could pose a risk of serious injury or death.

### **Disclaimer:**

While every effort has been made to ensure the accuracy of the information in this User Manual, KickAss Products does not accept liability for any errors or omissions. Additionally, please note that all specifications and functionalities are subject to change without prior notice.

### **Important:**

Prior to using your KickAss Inverter, it is essential that you thoroughly read and understand the entire User Manual. Any misuse of the product may result in damage to the unit and/or cause harm or serious injury to the user.



**FAILURE TO FOLLOW THESE INSTRUCTIONS  
MAY RESULT IN DEATH OR SERIOUS INJURY**



- **WARNING: ELECTRICAL SHOCK HAZARD** - Do not dismantle the inverter as it contains hazardous voltages internally. Any attempt to service internal components will void the warranty and could lead to fatal injuries.
- **WARNING: ELECTRICAL SHOCK HAZARD** - Avoid exposing the inverter to bilge water, rain, snow, spray, or dust. It is designed for indoor use only.
- **WARNING: ELECTRICAL SHOCK HAZARD** - Operating the inverter without proper grounding may result in death or serious injury. Ensure correct ground connections during installation. If you are unsure, consult a licensed electrician.
- **WARNING: ELECTRICAL SHOCK HAZARD** - Before cleaning the inverter, disconnect DC power and any connected circuits to avoid accidents.
- **WARNING: ELECTRICAL SHOCK HAZARD** - Keep the inverter away from children. Its 240V AC output should be treated with the same caution as household wall sockets.
- **WARNING:** Do not connect the inverter's output terminals to an incoming AC source under any circumstances. Doing so will cause permanent damage and nullify all warranties.
- **WARNING: EXPLOSION HAZARD** - Avoid using the inverter around flammable fumes or gasses, such as near gas bottles, petrol engines, or lead-acid battery compartments.
- **WARNING:** Avoid using substandard or damaged wiring with this inverter to prevent fire or shock hazards.
- **WARNING:** Pay close attention to the polarity when connecting the DC input. Reverse polarity connection will permanently damage the inverter and void the warranty.
- **WARNING:** When using inductive loads, be aware that they may draw up to ten times their rated power. Turn off any non-essential appliances connected to the inverter when running appliances with locked rotor currents, like pumps or compressors.
- **WARNING:** Ensure all ventilation and fan vents are unobstructed, and maintain a minimum of 60mm distance around the inverter's sides to allow proper ventilation. Failure to do so may result in fire or inverter failure.
- **WARNING:** Avoid dropping metal tools or heavy objects on the battery to prevent sparks or short circuits, which could lead to explosions.
- **WARNING:** Batteries can supply large currents in the event of a short circuit. Install a fuse on the positive supply cable close to the battery to provide adequate protection against short circuits and fire hazards.
- **LIMITATIONS OF USE:** Do not use the inverter with life support systems or other medical equipment or devices.

# TABLE OF CONTENTS

IMPORTANT SAFETY INFORMATION	2
FEATURES	5
SPECIFICATIONS	6
FRONT PANEL	7
KAPSWI2000 FRONT PANEL	7
KAPSWI3000 FRONT PANEL	9
REAR PANEL	11
KAPSWI2000 REAR PANEL	11
KAPSWI3000 REAR PANEL	12
REMOTE CONTROL DISPLAY (RCD)	13
INSTALLATION	15
CONNECTING THE INVERTER	18
OPERATING THE INVERTER	19
TROUBLESHOOTING	20
MAINTENANCE AND WARRANTY	22

# FEATURES

## **KAPSWI3000**

- RCD (Residual Current Device) protection
- ATS (Automatic Transfer Switch)
- Maximum efficiency of 94%
- Surge power: 6000W in 2 seconds
- Smart fan for efficient cooling
- Comprehensive protection including voltage, overload, current, short circuit, earth leakage, and reverse polarity
- Voltage alarm functionality
- 1x AC output, 1x USB charging port
- Optimal remote control display for easy monitoring and control

## **KAPSWI2000**

- RCD (Residual Current Device) protection
- ATS (Automatic Transfer Switch)
- Maximum efficiency of 94%
- Surge power: 4000W in 2 seconds
- Smart fan for efficient cooling
- Comprehensive protection including voltage, overload, current, short circuit, earth leakage, and reverse polarity
- Voltage alarm functionality
- 1x AC output, and 1x USB charging port
- 1 x AC, 1 x Terminal Block, 1 x USB Charging Port
- Optimal remote control display for easy monitoring and control.

# SPECIFICATIONS

Specification	KAPSWI2000	KAPSWI3000
Output Waveform	Pure Sine Wave <5%	Pure Sine Wave <5%
Input Voltage	12V DC (10~16V)	12V DC (10~16V)
Output Voltage	240V AC $\pm$ 5%	240V AC $\pm$ 5%
Output Rated Power	2000W	3000W
Surge Power 10 sec	2000W~2400W	3000W~3600W
Surge Power 2 sec	4000W	6000W
Frequency	50Hz $\pm$ 1Hz	50Hz $\pm$ 1Hz
Max Efficiency	94%	94%
High Voltage Protection	16V DC $\pm$ 0.5V DC	16V DC $\pm$ 0.5V DC
Low Voltage Protection	10V DC $\pm$ 0.5V DC	10V DC $\pm$ 0.5V DC
Built-In Auto Transfer Switch	Yes	Yes
Built-In Residual Current Device	Yes	Yes
Smart Cooling Fan	Yes	Yes
Environment Operating Temperature	-15°C ~ +40°C	-15°C ~ +40°C
Storage Temperature	-25°C ~ +75°C	-25°C ~ +75°C
Relative Humidity	20% ~ 90% RH non-condensing	20% ~ 90% RH non-condensing
Weight	5.7kg	7.8kg
Dimension without base or terminals (LWH)	386 x 220 x 110mm	386 x 220 x 150mm
Dimension with base and terminals (LWH)	440 x 220 x 110mm	470 x 220 x 150mm

# FRONT PANEL

## KAPSWI2000

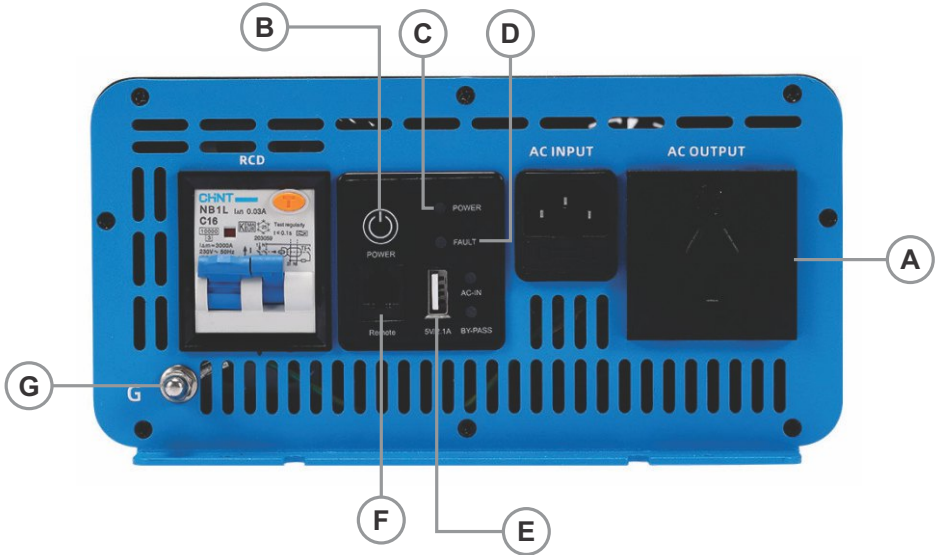

### **A. AC Output Receptacle**

Standard 10A 240V AC Australia / New Zealand receptacle.  
For connecting 240V AC appliances to the inverter.

### **B. Main Switch**

The main switch controls the output of the inverter, allowing you to turn it ON or OFF.

When switched ON, the Power LED Indicator (C) will glow green, accompanied by a single beep to signify the production of 240V AC power.

### **C. Power LED Indicator**

This LED Indicator glows green to indicate that the inverter is actively outputting 240V AC power.

#### **D. Fault LED Indicator**

The Fault LED Indicator will either glow or flash red when a fault is detected, and it will automatically turn off the 240V AC output. Refer to the troubleshooting section for further guidance.

#### **E. 5V USB Socket**

The USB Socket is designated for charging or powering 5V USB devices, such as mobile phones. Even when the Main Switch (A) is turned OFF, the 5V USB port will continue to supply power when the inverter is connected to a battery.

#### **F. Remote Control Port (RJ12)**

This port allows for connection to an optional remote control panel (available separately).

#### **G. Chassis Ground Terminal**

A secure ground connection is essential before operating the inverter. The grounding terminal, located on the front panel near the 240V outputs, ensures proper grounding. Connect the chassis ground terminal to the negative terminal of the DC input using a minimum 1.5mm<sup>2</sup> cable. Consult a licensed electrician to ensure compliance with current Australian/New Zealand standards.

## KAPSWI3000

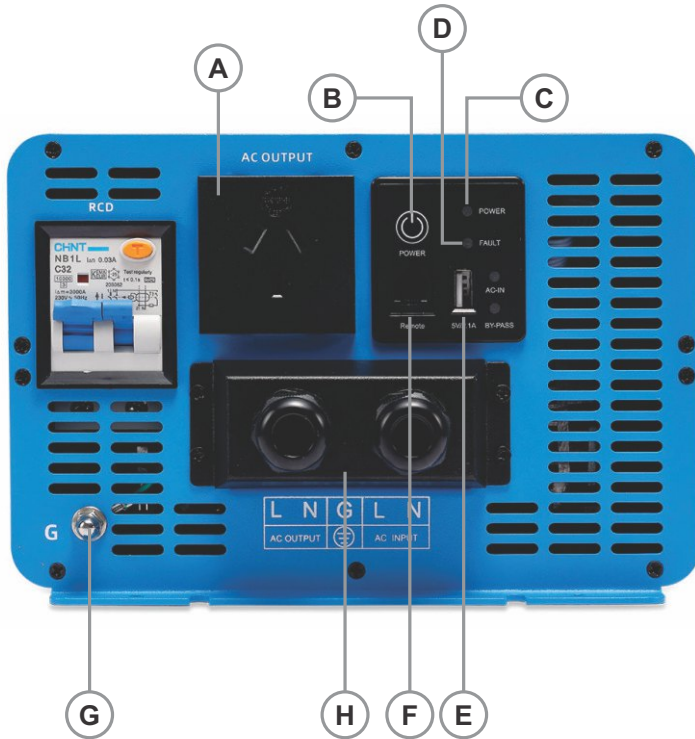

### **A. AC Output Receptacle**

Standard 10A 240V AC Australia / New Zealand receptacle.  
For connecting 240V AC appliances to the inverter.

### **B. Main Switch**

The main switch controls the output of the inverter, allowing you to turn it ON or OFF.

When switched ON, the Power LED Indicator (C) will glow green, accompanied by a single beep to signify the production of 240V AC power.

### **C. Power LED Indicator**

This LED Indicator glows green to indicate that the inverter is actively outputting 240V AC power.

#### **D. Fault LED Indicator**

The Fault LED Indicator will either glow or flash red when a fault is detected, and it will automatically turn off the 240V AC output. Refer to the troubleshooting section for further guidance.

#### **E. 5V USB Socket**

The USB Socket is designated for charging or powering 5V USB devices, such as mobile phones. Even when the Main Switch (A) is turned OFF, the 5V USB port will continue to supply power when the inverter is connected to a battery.

#### **F. Remote Control Port (RJ12)**

This port allows for connection to an optional remote control panel (available separately).

#### **G. Chassis Ground Terminal**

A secure ground connection is essential before operating the inverter. The grounding terminal, located on the front panel near the 240V outputs, ensures proper grounding. Connect the chassis ground terminal to the negative terminal of the DC input using a minimum 1.5mm<sup>2</sup> cable. Consult a licensed electrician to ensure compliance with current Australian/New Zealand standards.

#### **H. 3000W Inverter Hard-wire Terminal Block**

Connection Designations:

- L: Live/Active
- G: Ground/Earth
- N: Neutral

When using loads requiring 15Amps or more, it is important to use the hard-wire terminal block. Ensure that the terminal block cover is installed before activating the inverter.



**DANGER: ELECTRICAL SHOCK HAZARD**  
ONLY LICENSED ELECTRICIANS ARE PERMITTED TO CONNECT  
LOADS TO THE HARD-WIRE TERMINAL BLOCK.



# REAR PANEL

## KAPSWI2000

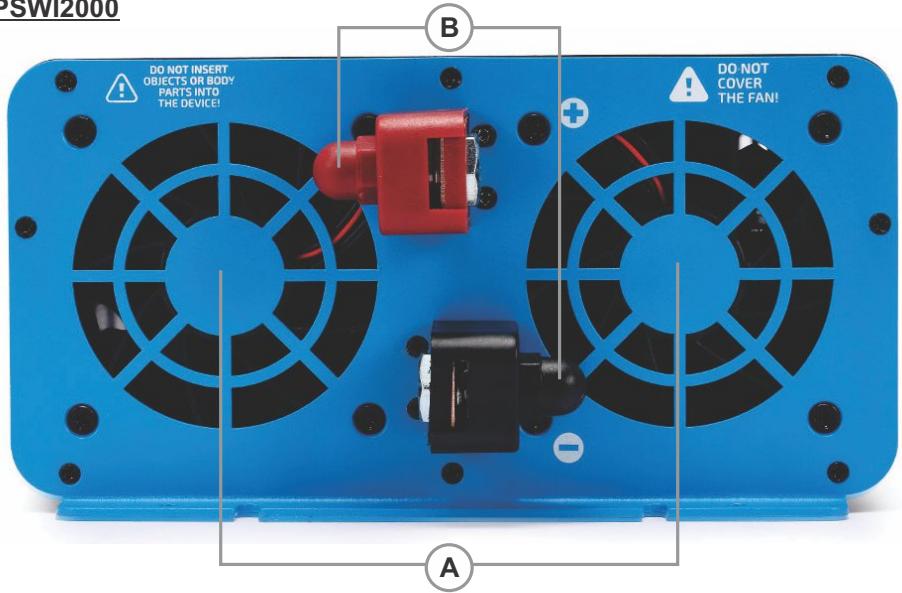

### A. Cooling Fan

The cooling fan(s) integrated into the inverter operate based on temperature and/or load conditions.

These fan(s) will activate automatically when the AC load reaches 20% or higher, or if the internal temperature surpasses 45°C.

### B. DC Input Terminals

Warning: Be careful when connecting the DC input, ensuring correct polarity. Reversing the polarity will result in irreversible damage to the inverter, voiding all warranties.

Warning: Installing a fuse or DC circuit breaker is essential; it should be positioned no more than 20cm from the positive terminal of your battery. Failure to install this protective measure could lead to a fire hazard.

Refer to the table below for the recommended cable size and fuse rating. It's essential to adhere to these guidelines for safe operation.

### Recommended Cable Size and Fuse Rating

MODEL	CABLE SIZE	FUSE/CIRCUIT BREAKER
KAPSWI2000	25mm <sup>2</sup> for lengths < 1M	250A

## KAPSWI3000

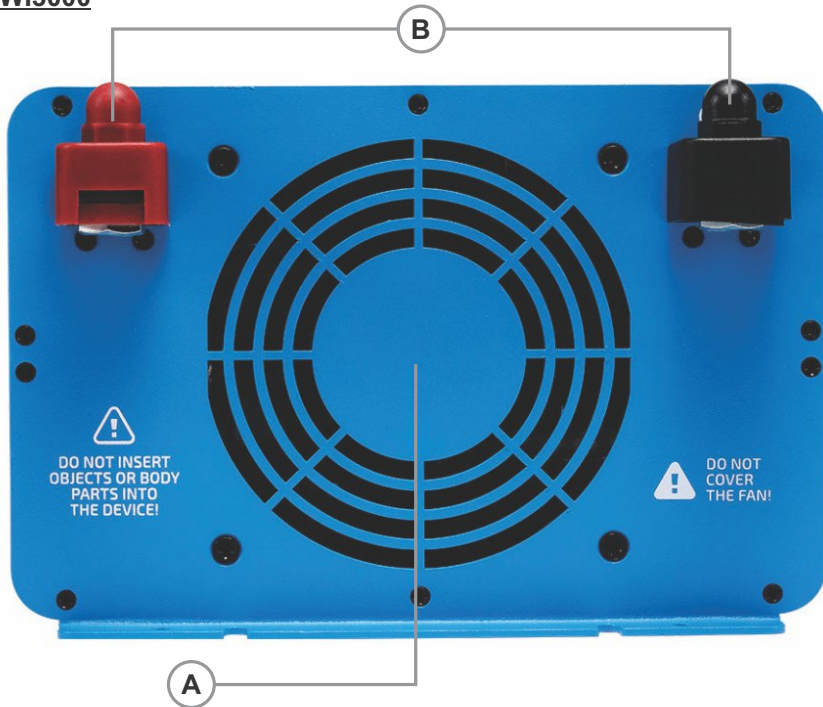

### **A. Cooling Fan**

The cooling fan(s) integrated into the inverter operate based on temperature and/or load conditions.

These fan(s) will activate automatically when the AC load reaches 20% or higher, or if the internal temperature surpasses 45°C.

### **B. DC Input Terminals**

Warning: Be careful when connecting the DC input, ensuring correct polarity. Reversing the polarity will result in irreversible damage to the inverter, voiding all warranties.

Warning: Installing a fuse or DC circuit breaker is essential; it should be positioned no more than 20cm from the positive terminal of your battery. Failure to install this protective measure could lead to a fire hazard.

Refer to the table below for the recommended cable size and fuse rating. It's essential to adhere to these guidelines for safe operation.

### **Recommended Cable Size and Fuse Rating**

MODEL	CABLE SIZE	FUSE/CIRCUIT BREAKER
KAPSWI3000	35mm <sup>2</sup> for lengths < 1M	450A

# REMOTE CONTROL DISPLAY (RCD)



SOLD SEPERATELY

## REMOTE CONTROL DISPLAY INVERTER MODE(1000W/2000W/3000W)

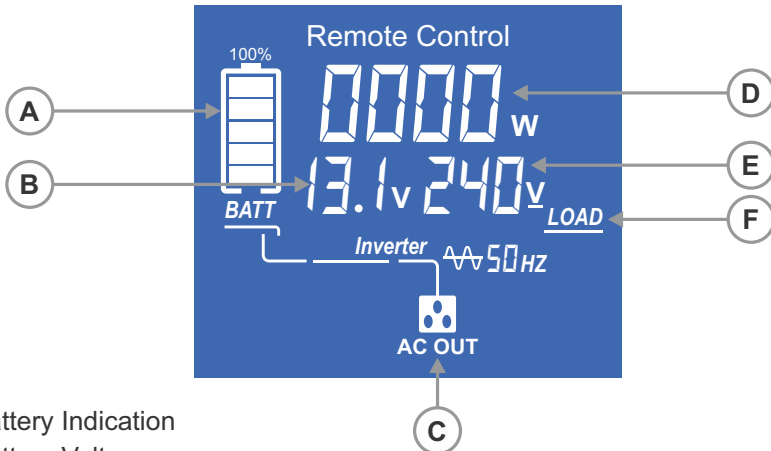

- A) Battery Indication
- B) Battery Voltage
- C) AC Output Running
- D) Power Consumption
- E) AC Output Voltage
- F) Inverter Operating

## REMOTE CONTROL DISPLAY AUTO TRANSFER MODE(1000W/2000W/3000W)

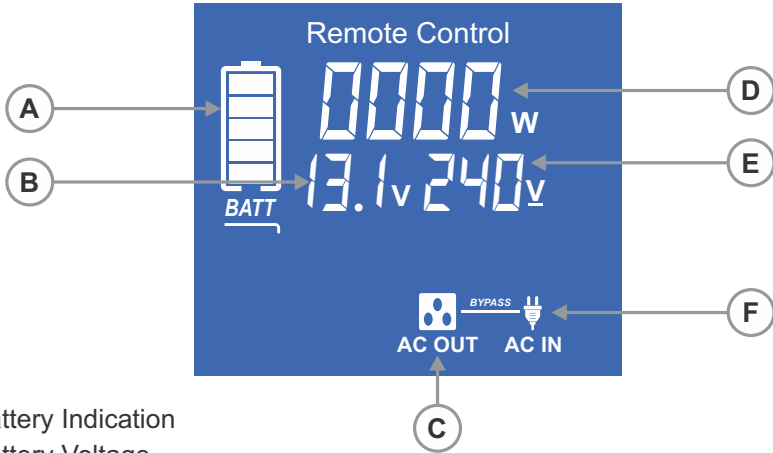

- A) Battery Indication
- B) Battery Voltage
- C) AC Output Running
- D) Power Consumption
- E) AC Output Voltage
- F) Mains Connected (transfer switch / by-pass)

## DISPLAY OF PROTECTION FUNCTION ---ERROR CODE

### E-1

Low voltage protection

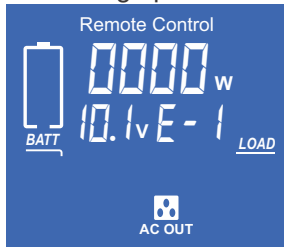

### E-2

Over voltage protection

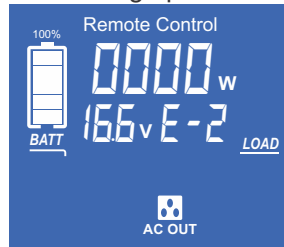

### E-3

High temperature

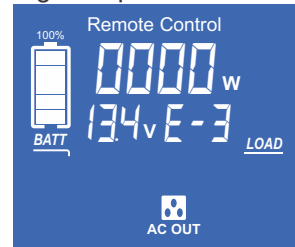

### E-4

Over load protection

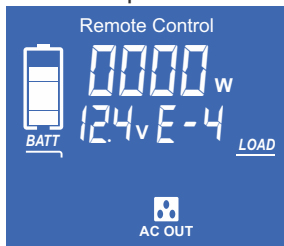

### E-5

Short circuit protection

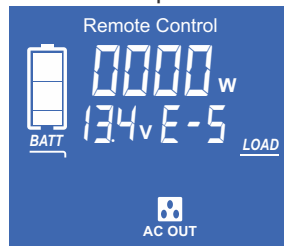

## CONNECTING THE REMOTE CONTROL

To set up the remote control, simply connect it to the inverter using the provided communications cable. This cable, a 6-conductor RJ12 type, is included with the remote control purchase. Ensure the cable is connected to the corresponding RJ-11 ports located at the rear of the remote and on the front panel of the inverter (referred to as Port F in Figures 1 and 2), noting that the connector follows a Straight Pinout configuration, not a Reverse one.

When using the remote control to power the inverter on or off, ensure that the Main Switch on the front panel of the inverter is set to the OFF position. Failure to do so will render the remote-control main switch inactive.

## INSTALLATION

### MOUNTING

The inverter has four slots in its mounting bracket that allow the unit to be fastened against a bulkhead, floor, wall or other flat surface. Ideally, the mounting surface should be cool to the touch. To avoid voltage drop install inverter as close as possible to the 12V DC power source (Battery). The inverter can be operated in any position, however, if it is to be mounted on a wall, mount it horizontally so that indicators, switches, outlets and terminal blocks located on the front panel are visible and accessible. If the inverter is to be installed in a moving vehicle, we strongly recommend that the inverter be shock-mounted either on the floor (in a clear, safe area) or on a secure flat surface.

When mounting the inverter, ensure the location meets the following criteria:

- **Dry:** Keep all liquids and moisture away from the unit.
- **Cool:** Avoid direct sunlight or nearby heat sources; maintain an ambient air temperature between 15°C to 25°C.
- **Ventilation:** Provide at least 60mm of clearance around the inverter to allow proper airflow, ensuring fans and vent holes remain unobstructed.
- **Safety:** Avoid installing the inverter in the same compartment as batteries to prevent corrosion, and steer clear of areas with flammable liquids or fumes.
- **Cleanliness:** Choose a dust-free environment to prevent dust from being drawn into the inverter, which could damage it.
- **Proximity to batteries:** Minimise cable lengths to prevent voltage drop and optimise inverter performance.

**Fuse:** Install a fuse between the battery and the inverter.

**Note:** Improper installation or usage of this inverter may result in radio frequency interference, potentially affecting radio communications. If interference occurs, consider reorienting or relocating affected antennas, increasing distance between the inverter and affected devices, or seeking assistance from a dealer or experienced technician.

## WARNING: ELECTRICAL SHOCK HAZARD

For your safety, KickAss Products strongly advises hiring a certified technician or licensed electrician to handle all wiring and installation tasks. This ensures compliance with relevant electrical wiring regulations and installation codes. Failure to adhere to these guidelines may lead to unit damage, as well as potential death or serious injury.



## WIRING

Follow this procedure to connect the battery cables to the DC input terminals of the inverter. Your cables should be sufficiently size to avoid voltage drop. We strongly recommend using the recommended cables as they are sized to avoid voltage drop. If cables are not an adequate gauge or length this will decrease the inverters performance such as poor surge capabilities, low input voltage warnings and shutdowns. Failure to use correct wiring will prompt under voltage protection warning. Ensure the cables are connected to the inverter correctly on the positive/red cable. Once the main battery cables are connected to your inverter it is ready for operation.

Wiring the batteries in parallel increases the total run time the batteries can operate the AC loads. A parallel connection combines overall battery capacity by the number of batteries in the string. In the example shown, four 12 VDC/100AH batteries are combined into a single 12VDC/400AH battery bank.



FUSE (NOT INCLUDED)

## EARTHING POINT

**In-Built Earthing Point** It is important to install a grounding wire from the unit's inbuilt earthing point to your chassis or a grounding pole. A grounding wire gives an appliance or electrical device a safe way to discharge excess electricity. By taking the electricity that builds up during a malfunction or surge and sending it outside of your circuit, into the ground.

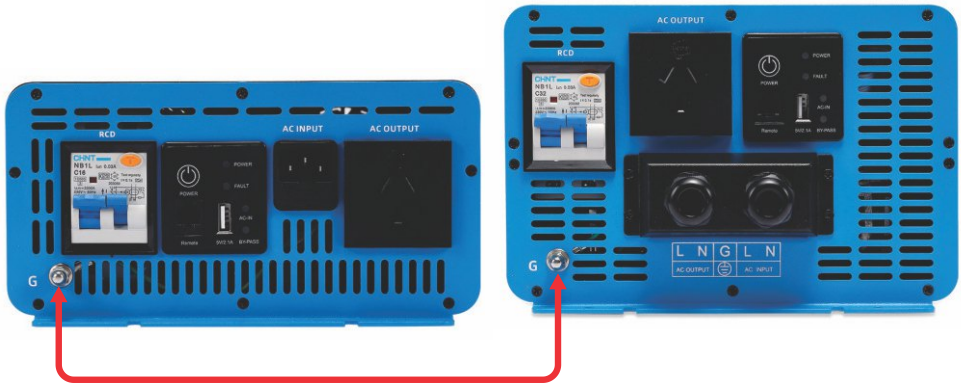

Earthing Connection Point

**Caution:** Exercise extreme care when connecting the DC input, ensuring correct polarity. A reverse polarity connection can result in irreversible damage to the inverter, nullifying all warranties.

## CONNECTING THE INVERTER

To properly connect the inverter, follow these steps:

1. Ensure both the main and remote main switches (if applicable) are in the OFF position.
2. Begin by attaching one end of the positive DC input cable to the inverter's positive DC input terminal. Then, connect the other end of this cable to one terminal of the fuse holder or circuit breaker. Next, link another DC input cable from the remaining terminal of the fuse holder/circuit breaker to the positive terminal of your battery.
3. Connect one end of the negative DC input cable to the inverter's negative DC input terminal. Then, attach the other end of this cable to the negative terminal of the battery.

### Caution:

1. When connecting the negative cable to the battery's negative terminal, expect some sparking due to the internal capacitor charging, which is normal.
2. For optimal performance, distribute the load across two batteries connected in parallel.
3. Ensure all DC connections are securely tightened to prevent overheating and potential fire hazards.

## OPERATING THE INVERTER

### **To operate the inverter:**

1. Ensure the connected AC appliance is switched OFF before powering up the inverter.
2. Activate the inverter by switching the Main Switch to the ON position.
3. Wait for the Power LED Indicator to illuminate, then proceed to switch ON the connected AC appliance.
4. When you have finished using the AC appliance, switch it OFF first, then deactivate the inverter by setting the Main Switch to the OFF position.

Please be aware that while the inverter can handle high surge power, doubling the rated output, certain appliances may still trigger overload protection. In such cases, consider using a larger inverter better suited to those appliances.

# TROUBLESHOOTING

SYMPTOM	POSSIBLE CAUSE	SOLUTIONS
The Main Switch is ON, but there is no 240V AC output or any LED indicator lights on.	There is no voltage at the DC input.	<ol style="list-style-type: none"> <li>1. Check that the battery fuse is intact and not blown.</li> <li>2. Check that all the DC input connections are tight.</li> <li>3. Check the continuity of the DC input circuit.</li> <li>4. If using a lithium battery, check to see if it has gone into protection/safe mode, if so, please follow your battery manufacturer's instructions on how to reset the battery.</li> </ol>
	The polarity of the DC input has been reversed and blown the internal fuses. (NOTE: This may have caused permanent damage to the inverter, and voided the warranty.)	The inverter will need to be returned to KickAss for further assessment.
The inverter beeps once, Power LED Indicator glows green. But the connected AC appliance does not turn on.	<ol style="list-style-type: none"> <li>1. Loose AC output connections.</li> <li>2. Short circuit of AC output wiring.</li> <li>3. The AC appliance is faulty.</li> </ol>	<ol style="list-style-type: none"> <li>1. Double-check that all AC output connections are tight and not loose. (Consult a licensed electrician.)</li> <li>2. Check for short circuits with your AC wiring.</li> <li>3. Test the AC appliance on your home's 240V AC wall socket.</li> <li>4. Turn on the AC appliance.</li> <li>5. If there is still no output, contact KickAss.</li> </ol>
The inverter beeps twice	Low DC input voltage warning. The voltage at the DC input reads below $10.5\pm 0.5\text{VDC}$	<ol style="list-style-type: none"> <li>1. Check that the battery is not flat and is fully charged. If low, recharge.</li> <li>2. Check that the battery cables are thick enough to carry the required current over the required length. Use thicker cable if required.</li> <li>3. Check for any loose connections on the DC input circuit.</li> </ol>
The inverter beeps 3 times and the Fault Indicator LED glows red, and there is no AC output.	Low DC input voltage shutdown warning. When the voltage at the DC input reads below $10.0\pm 0.5\text{VDC}$ , the AC output of the inverter will shut down.	<ol style="list-style-type: none"> <li>1. Check that the battery is not flat and is fully charged. If low, recharge.</li> <li>2. Check that the battery cables are thick enough to carry the required current over the required length. Use thicker cable if required.</li> <li>3. Check for any loose connections on the DC input circuit.</li> </ol>

<p>The inverter beeps 4 times and the Fault Indicator LED glows red, and there is no AC output.</p>	<p>Overvoltage detected on the DC input. When the voltage at the DC input reads higher than <math>16.0 \pm 0.5\text{VDC}</math>, the AC output will shut down.</p>	<ol style="list-style-type: none"> <li>1. Check that the voltage at the DC input terminals does not exceed 16VDC. If they do, attempt to lower the voltage of the battery and check battery charging voltages.</li> <li>2. Ensure that the maximum charging voltage of any chargers connected to the battery are set below 16.0VDC.</li> <li>3. Ensure that there are no unregulated charging sources connected to the battery, such as solar panels with no regulator.</li> </ol>
<p>The inverter beeps 5 times and the Fault Indicator LED glows red, and there is no AC output.</p>	<p>The inverter is overheating. When the internal temperature exceeds <math>75^{\circ}\text{C}</math> the AC output will shut down.</p>	<ol style="list-style-type: none"> <li>1. Reset the inverter by turning it off and on again and check to see if the cooling fan(s) are working (fans automatically turn on when the inverter is at 20% load or internal temperatures are at <math>45^{\circ}\text{C}</math>). If the cooling fans are not functioning, the inverter will need further assessment, please contact KickAss.</li> <li>2. If the fan is functioning, check that all ventilation slots and fan openings are not obstructed. Also ensure that adequate cool air is being circulated to the inverter and make sure ambient air temperatures do not exceed <math>45^{\circ}\text{C}</math>.</li> <li>3. Reduce the AC load on the inverter.</li> </ol>
<p>The inverter beeps 11 times and the Fault Indicator LED glows red, and the inverter shuts down.</p>	<p>The inverter has detected a short circuit with the AC output.</p>	<p>Please check that the connected device is not faulty, and that there are no short circuits in the AC circuit. Please consult a licensed electrician.</p>
<p>The inverter is beeping continuously and the Fault Indicator LED glows red, and there is no AC output.</p>	<p>The inverter has shut down due to overload. (Connected load has exceeded the surge rating of the inverter)</p>	<ol style="list-style-type: none"> <li>1. Disconnect the connected load.</li> <li>2. Reduce the connected load.</li> </ol>

# MAINTENANCE AND WARRANTY

## **Maintenance:**

Ensure the inverter is switched off before conducting any maintenance. Minimal maintenance is required to keep your inverter operating smoothly.

Periodically clean the exterior using a dry cloth to prevent dust and dirt accumulation.

Additionally, inspect and tighten the fasteners on the DC input terminals.

## **Warranty:**

KickAss Products guarantees this product against defects in materials and workmanship for a period of 24 months from the date of purchase. This warranty becomes void if the unit has been misused, altered, or accidentally damaged. KickAss Products will not be held liable for damages exceeding the retail purchase price of the unit under any circumstances. Incidental and consequential damages are expressly excluded from coverage under this warranty.

Please note that this inverter is not intended for commercial use. The warranty does not cover damage resulting from misuse or incorrect installation/connection, including wiring or connection to improper polarity sources.

## **Return/Repair Policy:**

In the unlikely event of a technical issue, please reach out to our online warranty page before returning the inverter.

If a unit is returned within the warranty period, KickAss Products will either repair or, at its discretion, replace it free of charge. Repairs may involve the use of new or reconditioned replacement parts, determined by the manufacturer. The replacement unit may be new or reconditioned, with a similar design. The repaired or replaced unit will then be covered under these terms for the remainder of the warranty period. Shipping charges for returning items to KickAss Products are the responsibility of the customer.

## **Limitations:**

This warranty does not extend to accessories such as adapters and batteries, nor does it cover defects or damage resulting from normal wear and tear (including but not limited to chips, scratches, abrasions, discoloration, or fading due to usage or exposure to sun or environmental elements). It also excludes damage from accidents, shipping to KickAss Products' service facility, unauthorized alterations, neglect, misuse, abuse, failure to follow care and maintenance instructions, as well as damage from fire or flood.

# KICKASS

**KickAss is a registered trademark of  
KickAss Products Pty Ltd**

**Designed & imported by  
KickAss Products Pty Ltd  
39 Iris Place, Acacia Ridge, QLD 4110  
Australia**

Made in China

