

KICKASS



25 AMP DC-DC CHARGER WITH MPPT SOLAR CONTROLLER

OWNER'S MANUAL

KADCDC25A-AND | KADCDC25A-BBK

V2.7

TABLE OF CONTENTS

WARNINGS -----	1
SPECIFICATIONS -----	3
BATTERY TYPE SPECIFICATIONS -----	3
PRODUCT OVERVIEW -----	4
INSTALLATION GUIDE -----	5
SAFETY FIRST -----	5
MOUNTING -----	5
DIMENSIONS -----	5
WIRING SIZE -----	6
WIRING INSTALLATION -----	7
WIRING DIAGRAM - KADCDC25A-AND -----	8
WIRING DIAGRAM - SOLAR PANEL ONLY -----	9
CHOOSING THE BATTERY TYPE -----	10
CHARGING STAGE PROFILE -----	10
UNDERSTANDING SOLAR, ALTERNATOR & CHARGING LIGHTS -----	11
FAULT CODES -----	13
WARRANTY DISCLAIMER -----	14

WARNINGS

- To avoid injury or damage to your vehicle ensure the instructions are read carefully and understood.
- Batteries can produce harmful vapour and explosive gases when being charged.
- Ensure batteries are mounted and stored in an area with good ventilation.
- As this Charger has powerful output current, circuit protection such as fuses or circuit breakers must be installed as near as possible to the batteries - refer to wiring diagrams in this manual for correct fitting.

This manual will give you all of the essential information you need to own and operate your new KickAss 25 AMP - DC-DC Charger with MPPT Solar Controller.

The purpose & features of the KickAss 25 AMP - DC-DC Charger with MPPT Solar Controller:

▶ **Can charge multiple battery types:**

Whether your battery is GEL, AGM, WET, CALCIUM or **Lithium LiFePO₄**.

▶ **Prevent your auxiliary battery from draining your start battery:**

Built-in voltage sensing will ensure your start battery charges your auxiliary battery when the vehicle is running. It will then disconnect the start battery from the auxiliary battery when the vehicle is not running.

▶ **Ensure your auxiliary battery is being fully charged and maintained:**

Most modern vehicles (especially those manufactured after 2010) do not provide the correct voltages and charge control to safely and completely charge your auxiliary battery. The Charger overcomes this issue by boosting the charge voltage to an optimal output level while ensuring your auxiliary battery is safely charged via its multi-stage charge algorithm.

▶ **When your vehicle is not charging, charge from the inbuilt MPPT solar controller:**

Maximum power point tracking is the most efficient type of solar controller and allows you obtain the maximum amount of charge from your solar panels. When your vehicle is not doing the charging, the built-in MPPT solar controller will let your solar panels do the work.

Stay safe and protect your assets with these protective features:

▶ **Short circuit protection**

The Charger will not turn on unless the batteries are connected correctly.

▶ **Reverse polarity protection**

If you connect positive and negative the wrong way around the Charger will show a fault.

▶ **Over voltage protection**

If the Charger detects voltages connected to its inputs or outputs that are too high it will shut down.

▶ **Over temperature protection**

The Charger will lower its output current if it senses that the unit will overheat.

▶ **Temperature compensation:**



The included temperature sensor will measure the battery temperature and adjust current accordingly to prevent overcharging.

**For more technical details, specifications & videos please visit
kickassproducts.com.au**

SPECIFICATIONS

Charger model	KADCDC25A-AND	KADCDC25A-BBK
Alternator input voltage	9-32V DC	
Input current (no load)	20mA	
Efficiency	App.95%	
External LED output current	4mA	
Max output current	Input 9-11V DC 20A	Input 11-32V DC 25A
Minimum auxiliary battery voltage	9V DC	
Input fuse rating	50A	
Output fuse rating	50A	
Maximum output power	368W	
Solar input voltage minimum voltage	9V DC	
Solar input maximum current	25A	
Solar input maximum voltage	32V DC	
Operating temperature	-10°C to +80°C	
Dimensions	165 x 120 x 40 mm	
Weight	1.11kg	0.96kg

BATTERY TYPE SPECIFICATIONS

Types of batteries	GEL, AGM, WET, CALCIUM			LITHIUM
Battery capacity range	75-300AH			50-250AH
Battery operation voltage	12V DC			
Integrated isolator cut in / cut out voltage	CUT IN 13.2V	CUT OUT 12.6V	CUT IN 26.4V	CUT OUT 25.2V
Integrated isolator (ignition override on)	CUT IN 12.2V	CUT OUT 11.6V	CUT IN 24.4V	CUT OUT 23.2V
Time delay function	There is a 30 second delay before charger will cut in or cut out.			
Certifications	 			
IP rating	IP67			

KICKASS constantly improves and innovates its products and we may from time to time discontinue or update product specifications without notice. For the latest product information and specifications, please visit KICKASS.com.au

PRODUCT OVERVIEW

KADCDC25A-AND

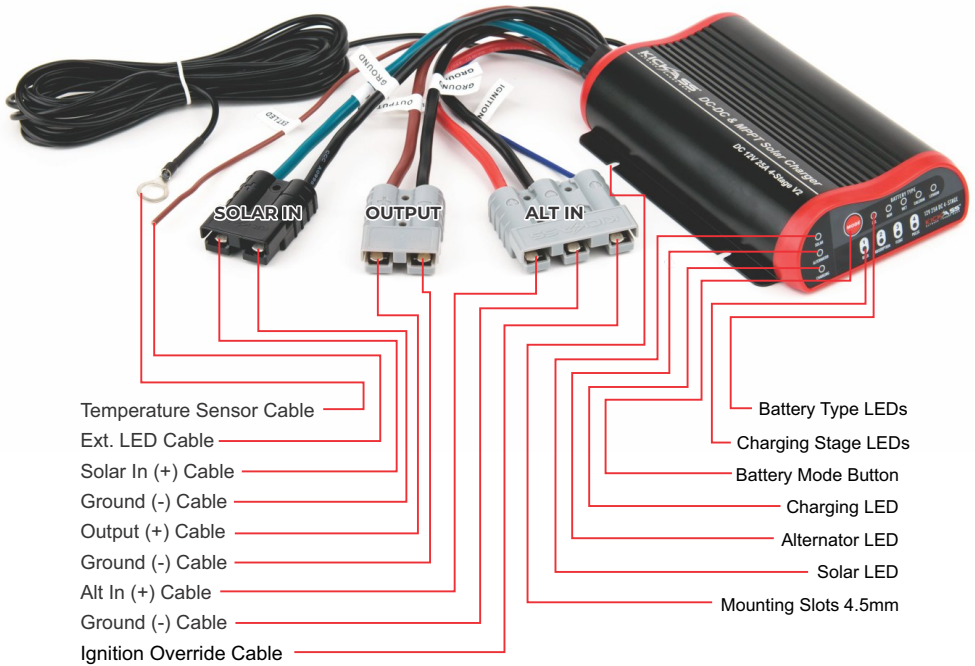

KADCDC25A-BBK

KADCDC25A-BBK will be delivered with all cables connected, which is already installed to a KickAss battery box. The button and indicators are the same as KADCDC25A-AND model above.

INSTALLATION GUIDE

SAFETY FIRST!

- ▶ The KickAss Charger has been engineered to charge 12 Volt GEL, AGM, WET, CALCIUM or Lithium LiFePO₄ only. Do not use this charger for any other purpose or with any other battery types.
- ▶ Do not attempt to charge known faulty, damaged, frozen or broken batteries.
- ▶ Ensure charger is close to battery, however never mount the charger directly on the battery.
- ▶ Ventilation is very important in battery charging, always ensure battery positioning is in a well ventilated area to allow charging gases to dissipate.
- ▶ Keep sparks or flames away from batteries being charged as they could emit explosive gases.
- ▶ Always check the batteries and charging system periodically to ensure no faults occur.
- ▶ Ensure all cabling is secure and cannot be cut, broken or short circuited.
- ▶ Battery acid is corrosive. If acid comes into contact with skin or eyes, please seek medical advice.
- ▶ Never connect this charger to mains supply.
- ▶ We recommend fitting a 50-75 amp fuse on both the input and output sides of the charger such as the SKU: KAMAXIFHAND or SKU: KAFUSECOVER-KIT to protect cables from short circuits etc.

MOUNTING

It is most important to mount your KickAss Charger as close as possible to your auxiliary battery and be sure to keep your charger away from sources of heat. eg. Turbos and exhaust pipes. This will ensure maximum performance out of your charger.

DIMENSIONS

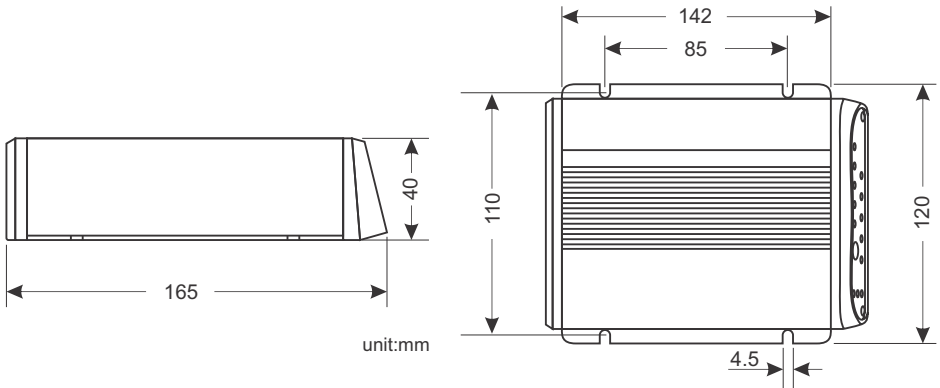

WIRING SIZE

To make sound electrical connections, the battery cable should be the correct size and the correct terminals should be crimped or soldered.

WIRES	CABLE SIZE
Alternator output cable (red)	8mm ² (8 B&S)
Solar input cable (green)	8mm ² (8 B&S)
Output cable (brown)	8mm ² (8 B&S)
Common ground (black)	8mm ² (8 B&S)
Ignition override (blue)	1.5mm ²
External LED indicator (brown)	1.5mm ²

Note:

The above recommendation is for cable length up to 8 meters.

For more information or assistance, see installation videos at kickassproducts.com.au

WIRING INSTALLATION

KADCDC25A-AND

The KADCDC25A-AND features quick connecting 50A Anderson style connectors and a single 3 pin Anderson style connector. We recommend using this with our KADBWK8MMPP wiring kit for fast and easy installation.

FOR SOLAR PANEL ONLY INSTALLATION

The KickAss Charger can be used with a solar only input so you can take advantage of the inbuilt MPPT solar regulator. Please refer to page 9 for the wiring diagram for solar panel only installation.

NOTE: The maximum solar input is 25 Amps.

Any existing regulators inline with the solar panels should be removed or bypassed.

Once installation is completed you will need to set the battery type, please refer to “CHOOSING YOUR BATTERY TYPE” on page 10 to ensure your KICKASS Charger is operating correctly.

WIRING DIAGRAM - KADCDC25A-AND

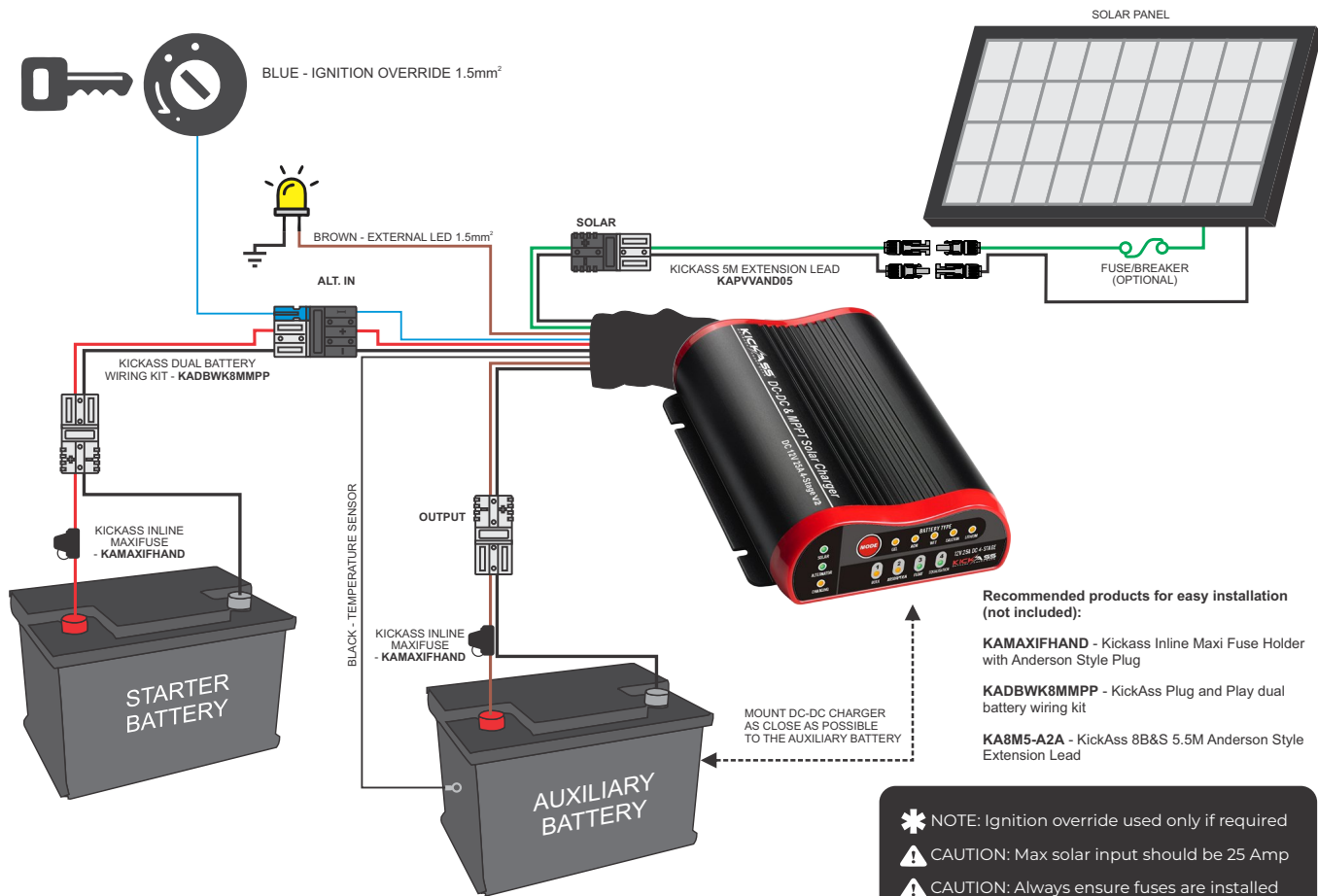

WIRING DIAGRAM - SOLAR PANEL ONLY

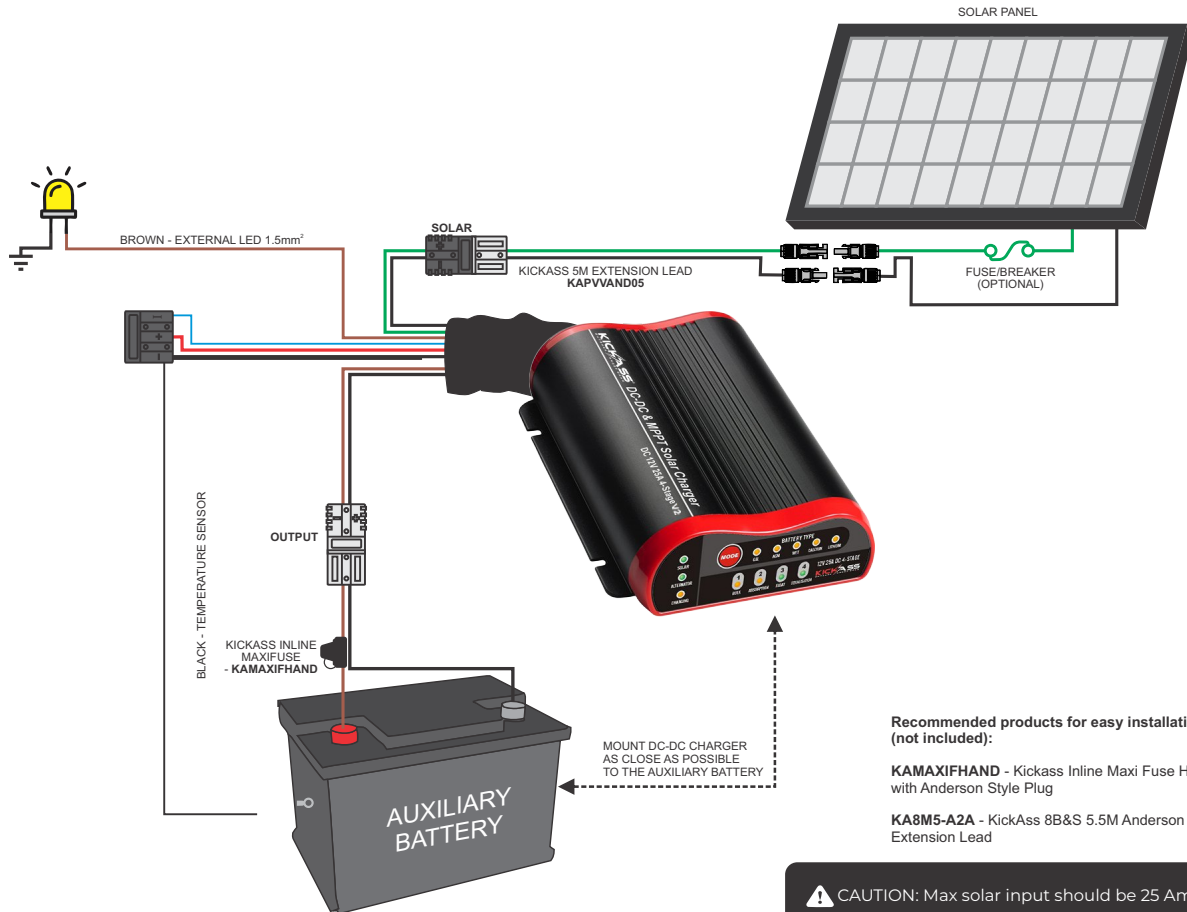

Recommended products for easy installation (not included):

KAMAXIFHAND - Kickass Inline Maxi Fuse Holder with Anderson Style Plug

KA8M5-A2A - KickAss 8B&S 5.5M Anderson Style Extension Lead

- ⚠ CAUTION: Max solar input should be 25 Amp
- ⚠ CAUTION: Always ensure fuses are installed

CHOOSING THE BATTERY TYPE

The default battery setting is **AGM**.

When the auxiliary battery is connected, press and hold the mode button for 5 seconds or until the battery light starts flashing. Then select from either **GEL, AGM, WET, CALCIUM** or **LITHIUM** and wait for the battery light to stop flashing. When this occurs, your selection is saved.

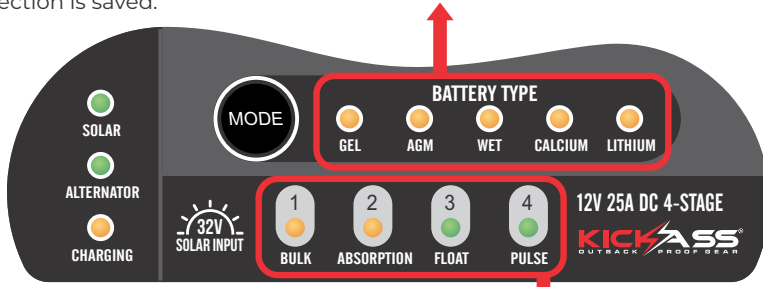

CHARGING STAGE PROFILE

STAGE	DESCRIPTION				
BULK	GEL 100% Current Until 14.1 V	AGM 100% Current Until 14.4 V	WET 100% Current Until 14.7 V	CALCIUM 100% Current Until 15.4 V	LITHIUM 100% Current Until 14.4 V
ABSORPTION	Constant 14.1 V Until 3.8A	Constant 14.4 V Until 3.8A	Constant 14.7 V Until 3.8A	Constant 15.4 V Until 3.8A	Constant 14.4 V Until 3.8A
FLOAT	13.7V at 100% Current Max				
PULSE	Begins after a continuous float stage of 10 days and pulses power through the battery using the same current and voltage as the absorption stage to maintain charge and desulphate. During this time, if the voltage of the auxiliary battery drops below 12.6V, the charger will restart the charge cycle at Bulk. Once pulse is completed, the charger reverts to float stage.				
FLOAT STAGE RESTART	12.8V			13.1V	

* Float Stage Restart refers to the voltage at which the charger will restart and return to the Bulk Stage.

UNDERSTANDING SOLAR, ALTERNATOR & CHARGING LIGHTS

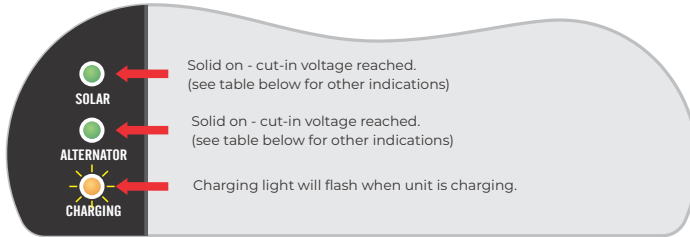

NOTE

- Alternator has priority over solar therefore, if both solar and alternator are connected, only alternator LED is solid and alternator is charging.
- 30 sec delay between cut-in voltage being reached and charging beginning & a 60 second delay before disconnecting when under cut-out voltage.

Alternator LED indicator

Alternator voltage 12V	Alternator voltage 24V	Alternator LED	Status
0-8.9 Volts	12-17.9 Volts	OFF	Under operating voltage
9-12.7 Volts	18-25.2 Volts	Flash 1 sec on 5 sec off	Under cut-out voltage
12.7-13.1 Volts	25.3-26.3 Volts	Flash 1 sec on 1 sec off	Under cut-in voltage
13.2 Volts	26.4 Volts	Solid on	Cut-in voltage reached, charging will start after 30 second delay

Alternator LED indicator with **ignition override wire connected**

Alternator voltage 12V	Alternator voltage 24V	Alternator LED	Status
0-8.9 Volts	12-17.9 Volts	OFF	Under operating voltage
9-11.6 Volts	18-23.2 Volts	Flash 1 sec on 5 sec off	Under cut-out voltage
10.6-12.1 Volts	23.3-24.3 Volts	Flash 1 sec on 1 sec off	Under cut-in voltage
12.2 Volts	24.4 Volts	Solid on	Cut-in voltage reached, charging will start after 30 second delay

Solar LED status

Solar voltage	Solar LED	Status
0-8.9 Volts	OFF	Under cut-in voltage
9 Volts	Solid on	Cut-in voltage reached, charging will begin after 10 sec delay (please note alternator has priority over solar)

Lithium BMS Sleep Mode & Recovery Feature:

Most lithium batteries are built with a Battery Management System (BMS) inside to protect the battery from over charging, over discharging and extreme temperature changes.

One of the key functions of the BMS is to protect your battery by internally disconnecting the load¹ when voltage drops below specific parameters, this will then result in the battery entering into a "sleep" mode.

¹ (Load includes any accessories and/or device/s drawing charge from the battery. Eg: fridges, pumps, food sealers, etc)

The KickAss DCDC MPPT Solar Battery Charger has a lithium battery recovery function. This function has been designed to recover lithium batteries from a sleep mode.

Lithium Battery Sleep Mode Indication:

When the lithium battery has entered sleep mode, the charger will show fault codes of output open circuit, until all loads¹ are disconnected and a sufficient charge source is connected.

(see "Battery Type Specification" on Page 3)

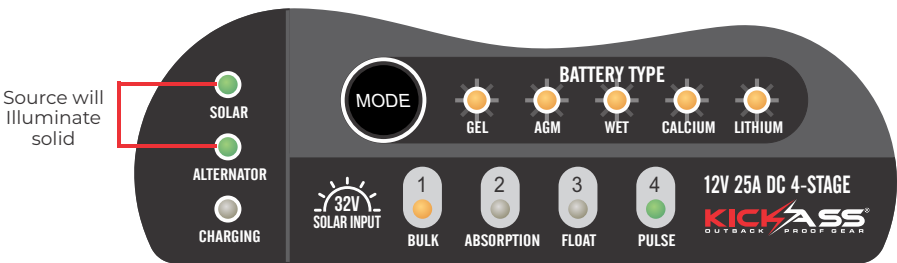

IMPORTANT : You must select 'LITHIUM' as the battery type by using the 'MODE' button prior to connecting it to a lithium battery in sleep mode to attempt recovery.

How to Wake a Lithium Battery to Begin Recovery Mode:

First disconnect any load connected to the lithium battery.

Secondly connect Alternator Input or Solar Input² to the KickAss DCDC MPPT Solar Battery Charger. Thirdly connect the output from the DCDC charger to the lithium battery. The Charger will have all battery types (GEL, AGM, WET CALCIUM, LITHIUM) flashing and the BULK and PULSE LED lights will remain on for 30 seconds (Indicated in diagram above,) before entering Recovery Mode.

²(Alternator and Solar inputs must be above cut-in voltage for DCDC Charger - see "Battery Type Specification" on Page 3)

Recovery Mode Indicator:

When the lithium battery has entered recovery mode, the KickAss DCDC MPPT Solar Battery Charger display will have the source indicator illuminated (eg; SOLAR) and the battery type LITHIUM will be flashing. See diagram below.

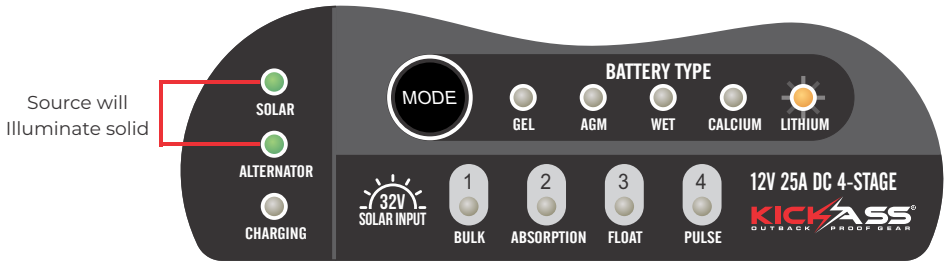

When the battery voltage has been recovered to 12V, the DCDC charger will automatically change to normal stage charging programs and loads may be reconnected.

FAULT CODES

If all battery type selection lights are flashing simultaneously please see troubleshooting guide below.

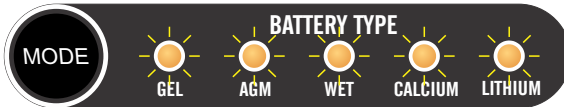

There are error codes that may be displayed. These will be displayed in the following way:

Stage LED	Bulk	Absorption	Float	Pulse	Cause	Remedy
Solar input high voltage	●		●		Over voltage is detected at solar input	Check solar panel open circuit voltage
Solar input reverse		●		●	Solar input is reversely connected	Check solar input connection
Alternator high voltage	●	●			Overvoltage is detected at alternator input	Check vehicle battery voltage
Alternator input reverse		●	●		Alternator input is reversely connected	Check alternator input connection
Output fault mode	●			●	Output battery is reversely connected	Check output cable connection
					Overvoltage is detected at output	Check auxiliary battery voltage
					Output open circuit or dead battery	Check auxiliary battery voltage & cable connections

NOTE: To activate the Charger when the auxiliary battery is below 9V, for a short period of time. You can then remove the jumper cables.

KICKASS PRODUCTS PTY LTD. WARRANTY DISCLAIMER

At Kickass Products Pty Ltd., we stand behind the quality and durability of our outdoor and camping products. Our product team rigorously tests every item in demanding conditions to ensure performance in normal use environments.

Limited Warranty Coverage

Kickass Products Pty Ltd. warrants that our products are free from manufacturing defects in materials and workmanship for the applicable warranty period. If a defect arises within this period, we will, at our discretion, repair, replace, or provide an appropriate remedy in accordance with Australian Consumer Law (ACL).

Exclusions

Warranty does not cover:

- Normal wear and tear
- Misuse, abuse or improper installation
- Damage caused by accidents, modifications, or lack of proper maintenance
- Consumable parts, unless a defect in materials or workmanship is present

Making a Warranty Claim

To initiate a claim, please retain your proof of purchase and contact our customer service team with details of the defect. We will guide you through the process, including potential return or assessment requirements.

Your Rights Under Australian Consumer Law

This warranty is in addition to any rights or remedies you may have under the ACL and does not exclude, restrict, or modify them.

Thank you for choosing Kickass Products Pty Ltd. We are committed to ensuring your outdoor adventures are backed with confidence.

KICKASS

**KickAss is a registered trademark of
KickAss Products Pty Ltd**

**Designed & imported by
KickAss Products Pty Ltd
39 Iris Place, Acacia Ridge, QLD 4110
Australia**

MADE IN CHINA