

#11

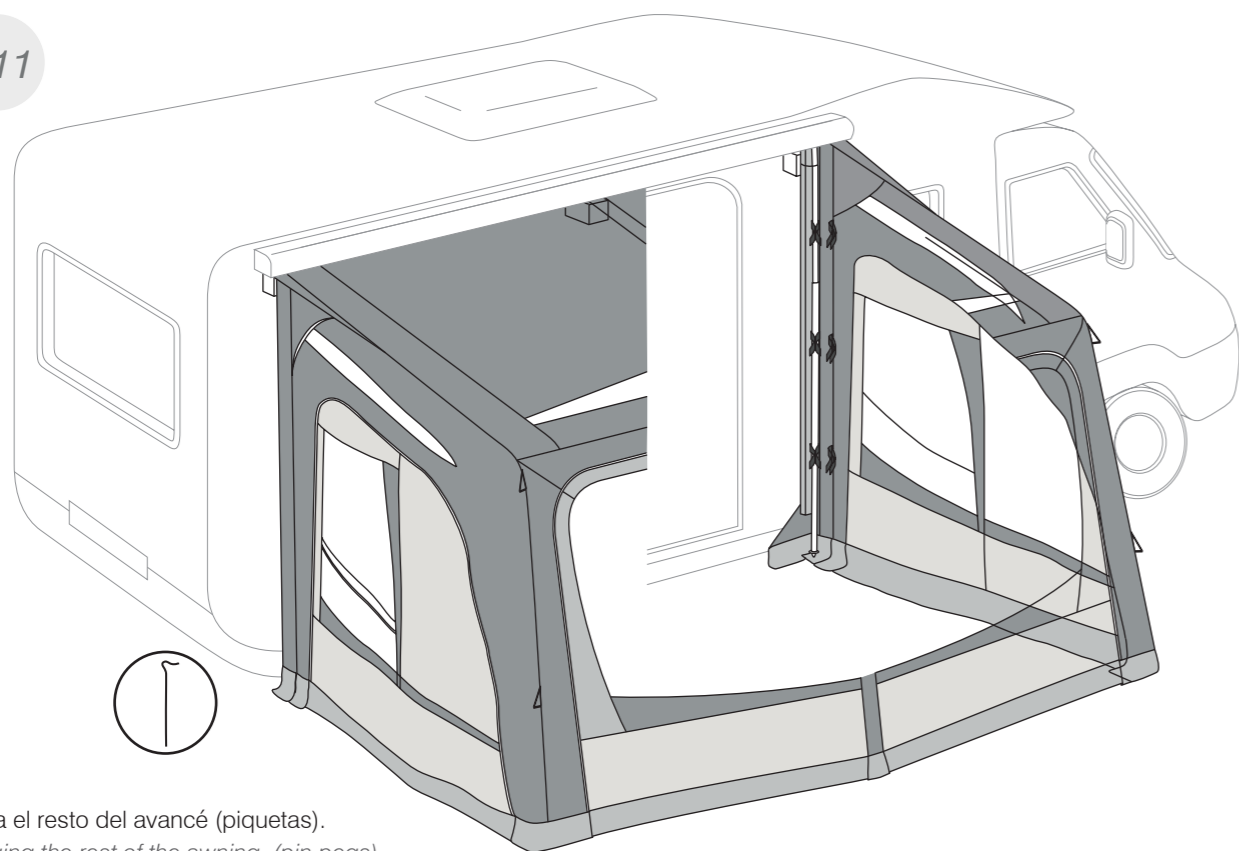

Clava el resto del avancé (piquetas).
Pegging the rest of the awning. (pin pegs).

#12

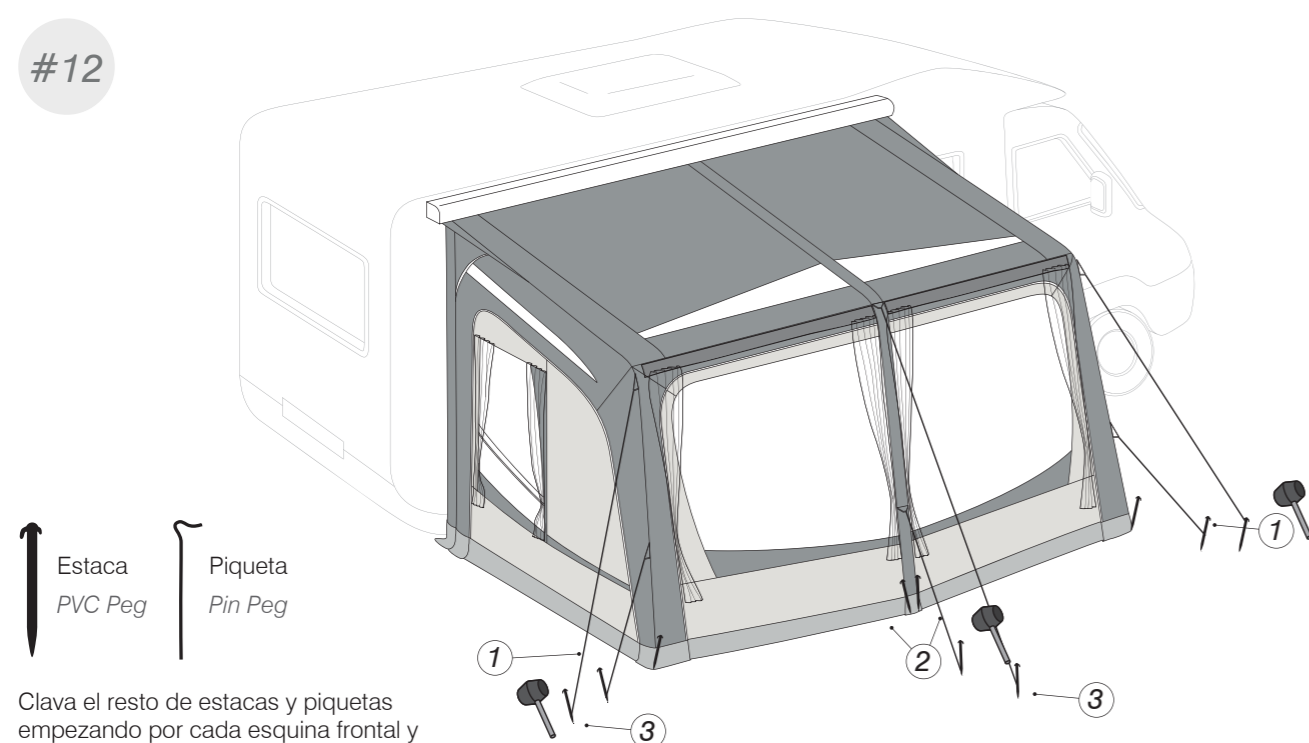

Clava el resto de estacas y piquetas empezando por cada esquina frontal y siguiendo por el centro. Clava las restantes dando suficiente tensión. Coloca las cortinas teniendo en cuenta que las cortinas frontales son más largas que las laterales. La guía de cortina frontal se encuentra debajo del tubo transversal.

Continue pegging the tent, first each front side and then central column. You can peg all the remaining points giving an appropriate tension. Hang the curtains being aware that the front curtains are longer than the side ones. The front curtain guide is under the small air tube.

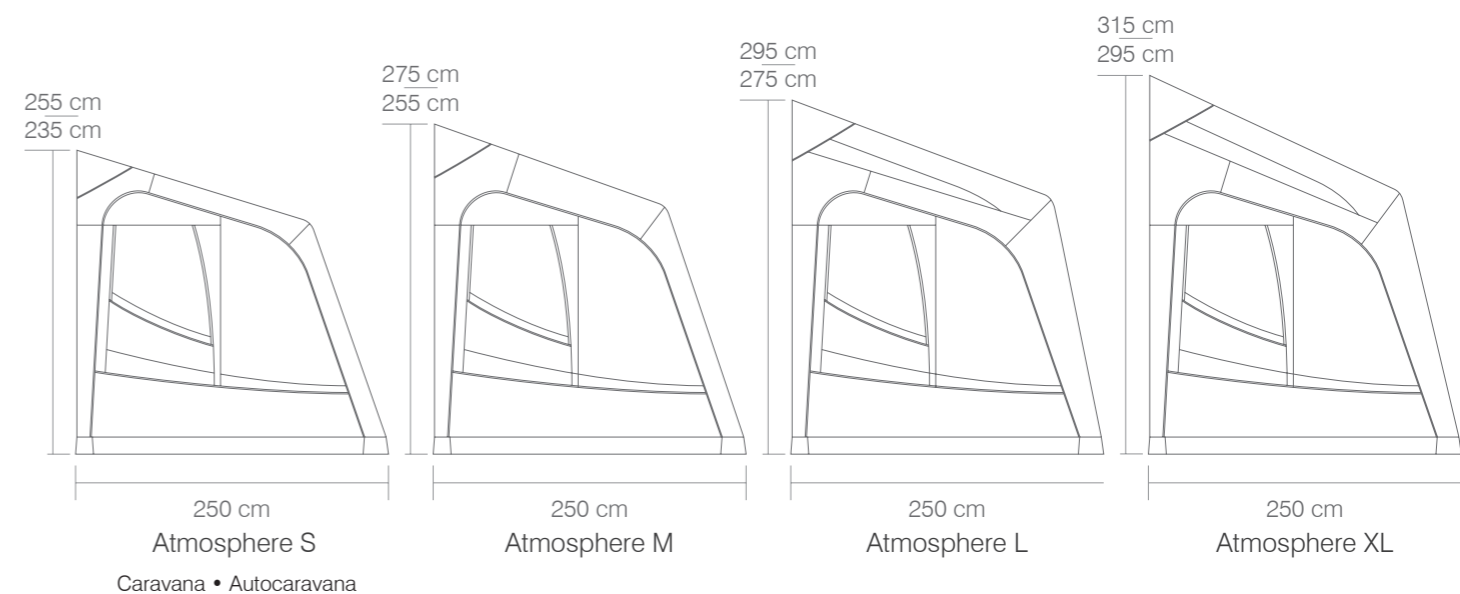
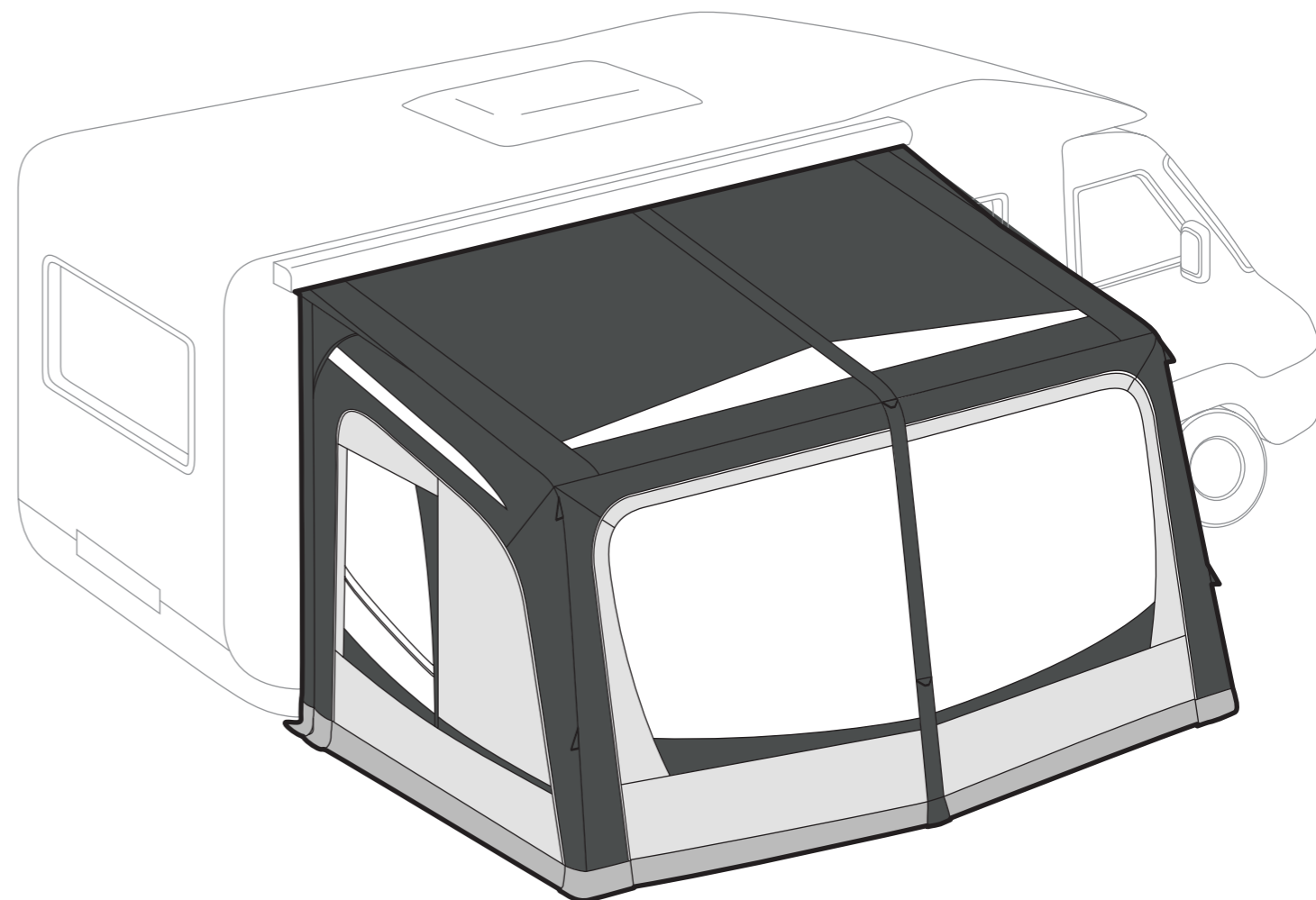

#1

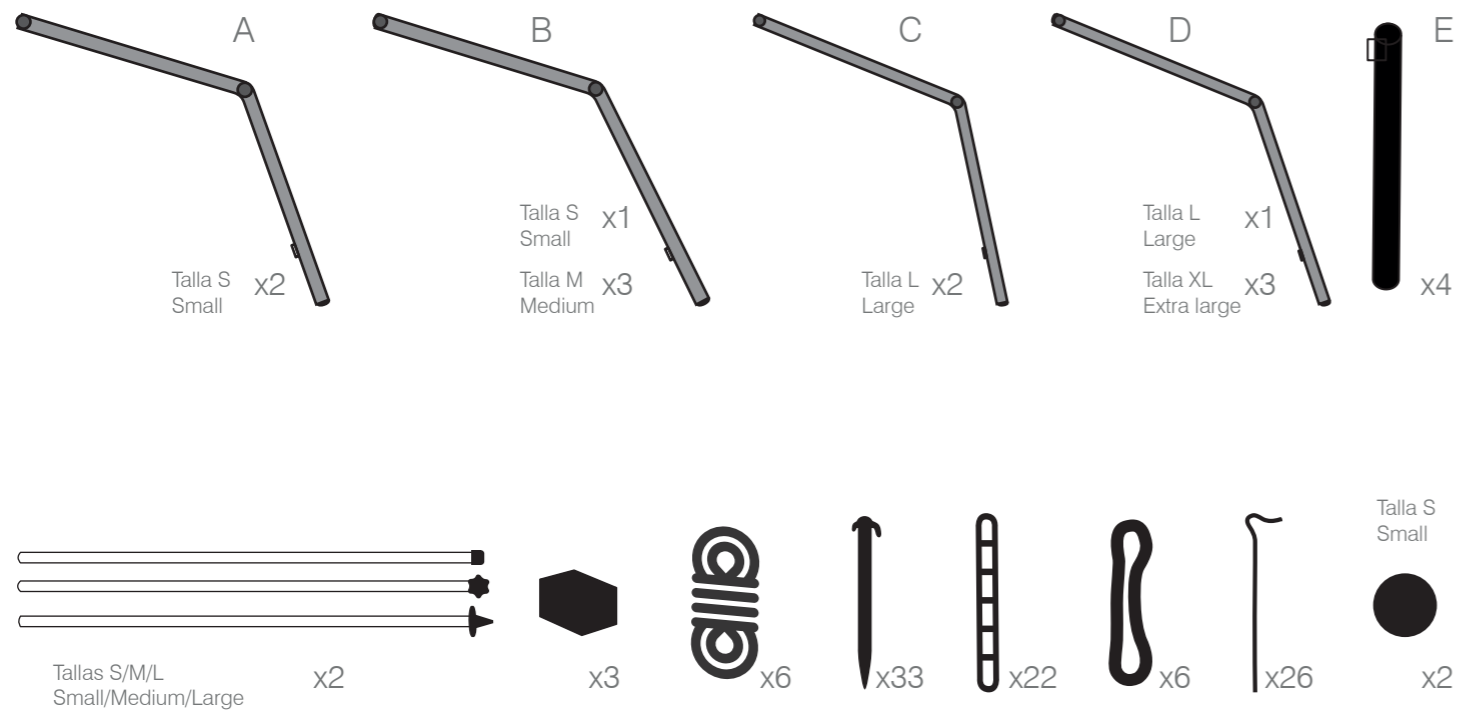
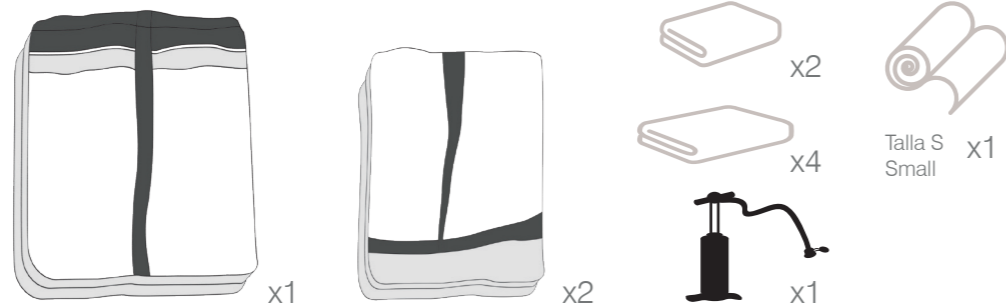
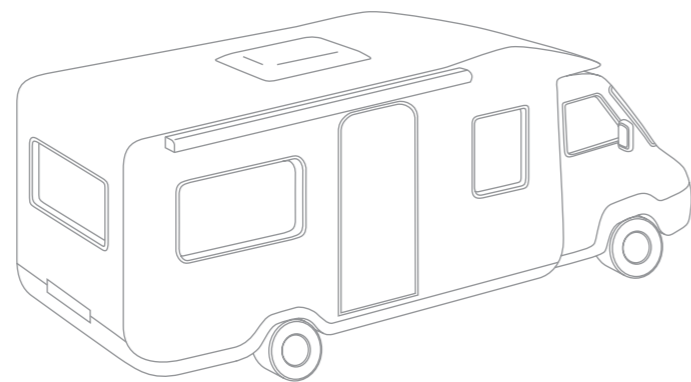

#9

Opción toldo de pared Wall canopy option

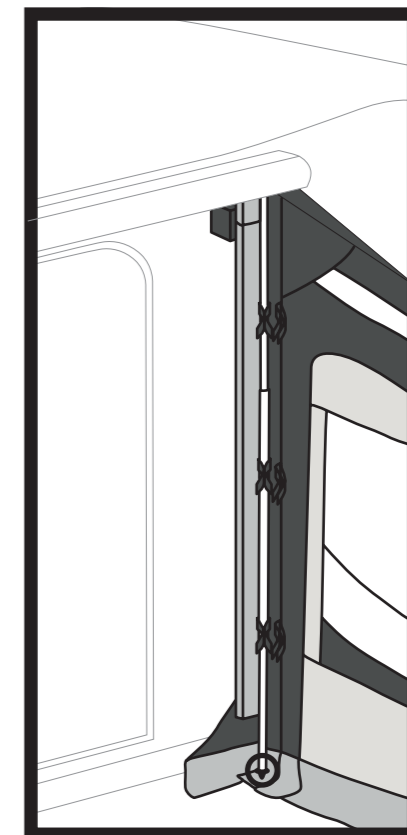
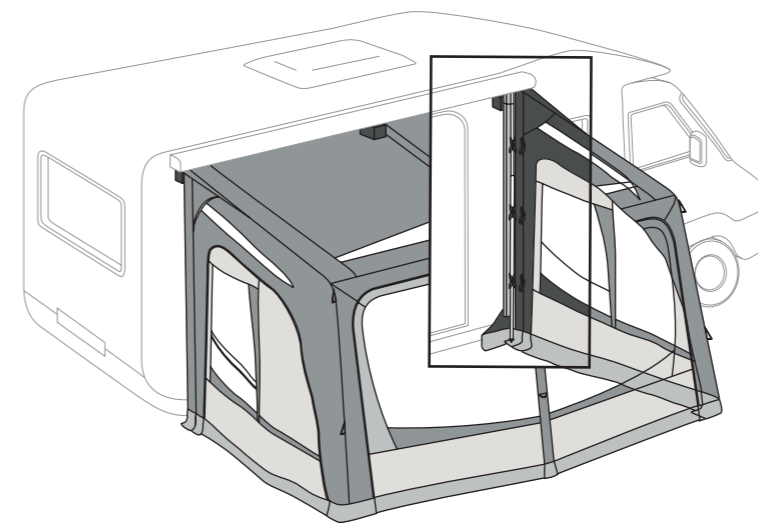

La extensión lateral cierra el espacio entre el vehículo y el avancé. La pata trasera presiona la espuma y se inserta dentro del bolsillo de la extensión.

The extra side close the gap between vehicle and awning. The back pole push the foam and get into the pocket placed on the top of the extra side.

#10

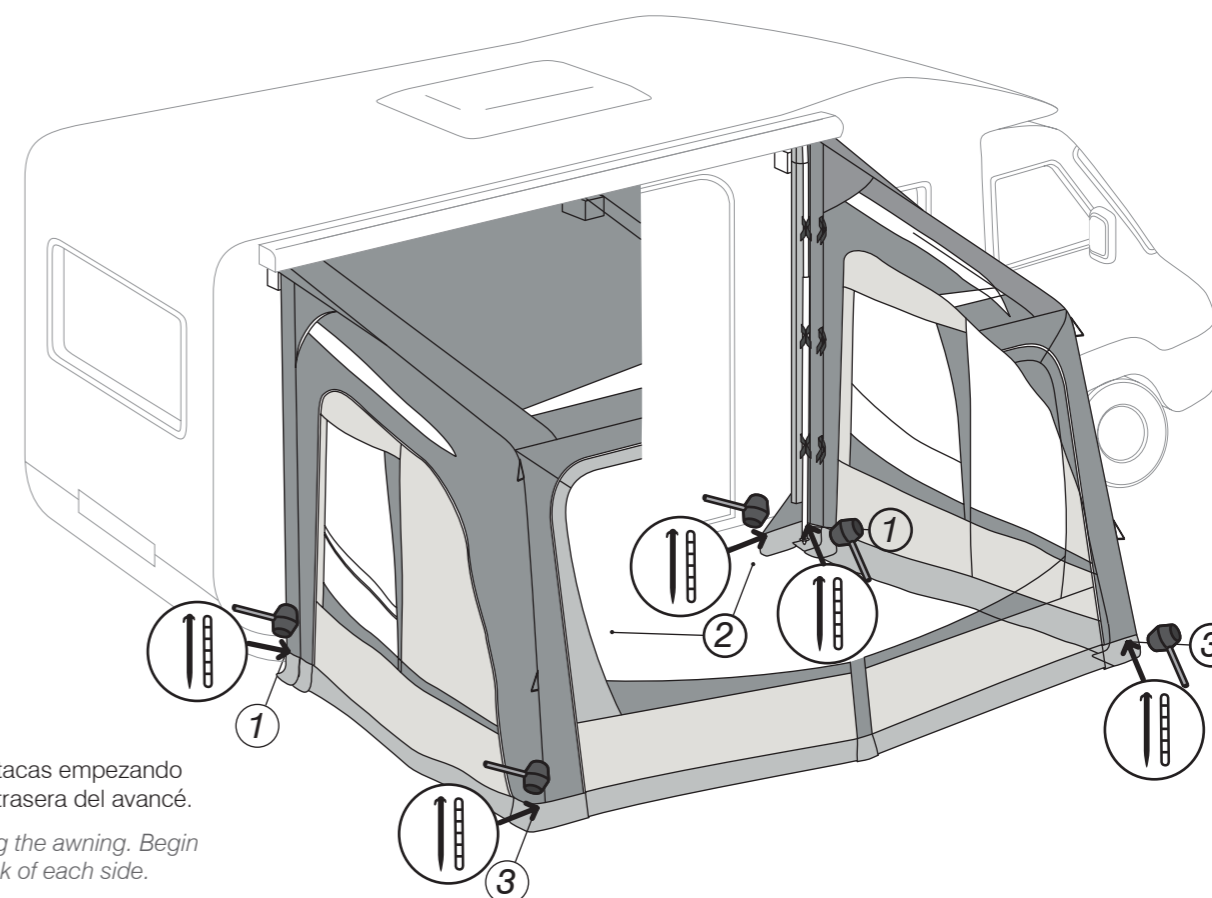

Clava las estacas empezando por la parte trasera del avancé.

Start pegging the awning. Begin from the back of each side.

#8

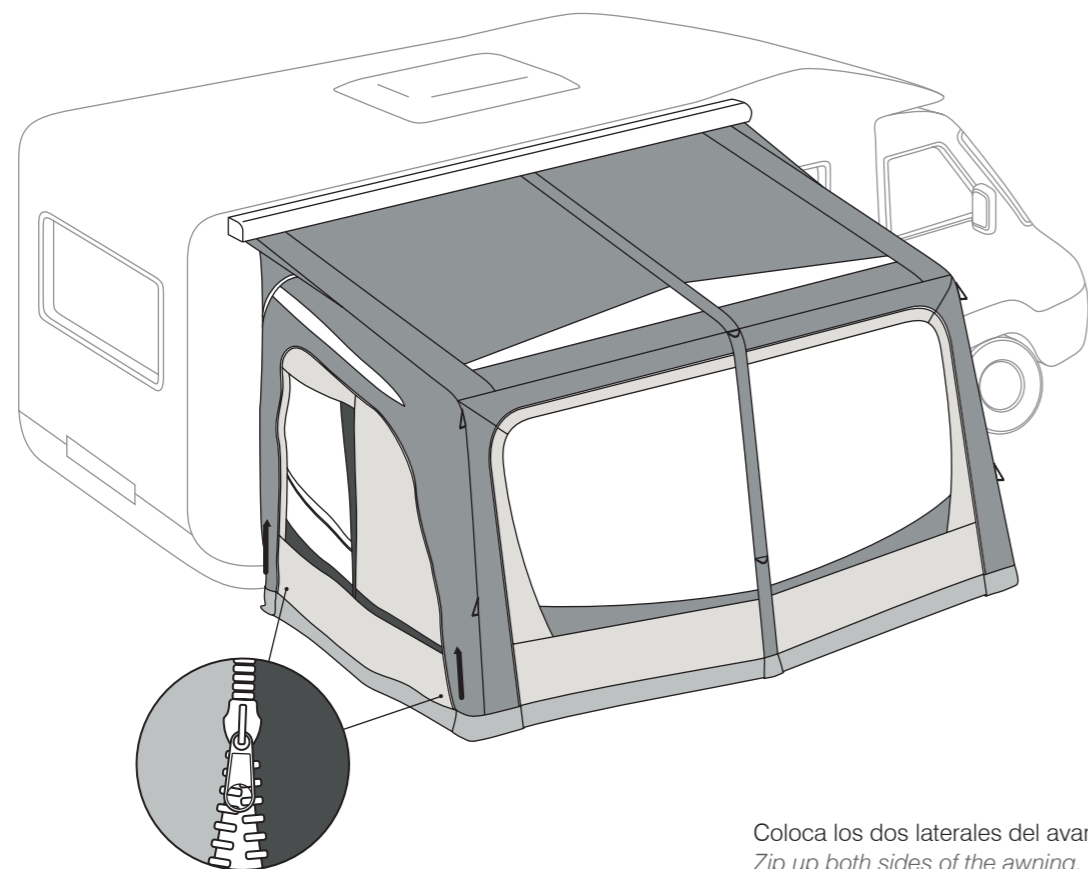

Coloca los dos laterales del avancé.
Zip up both sides of the awning.

#2

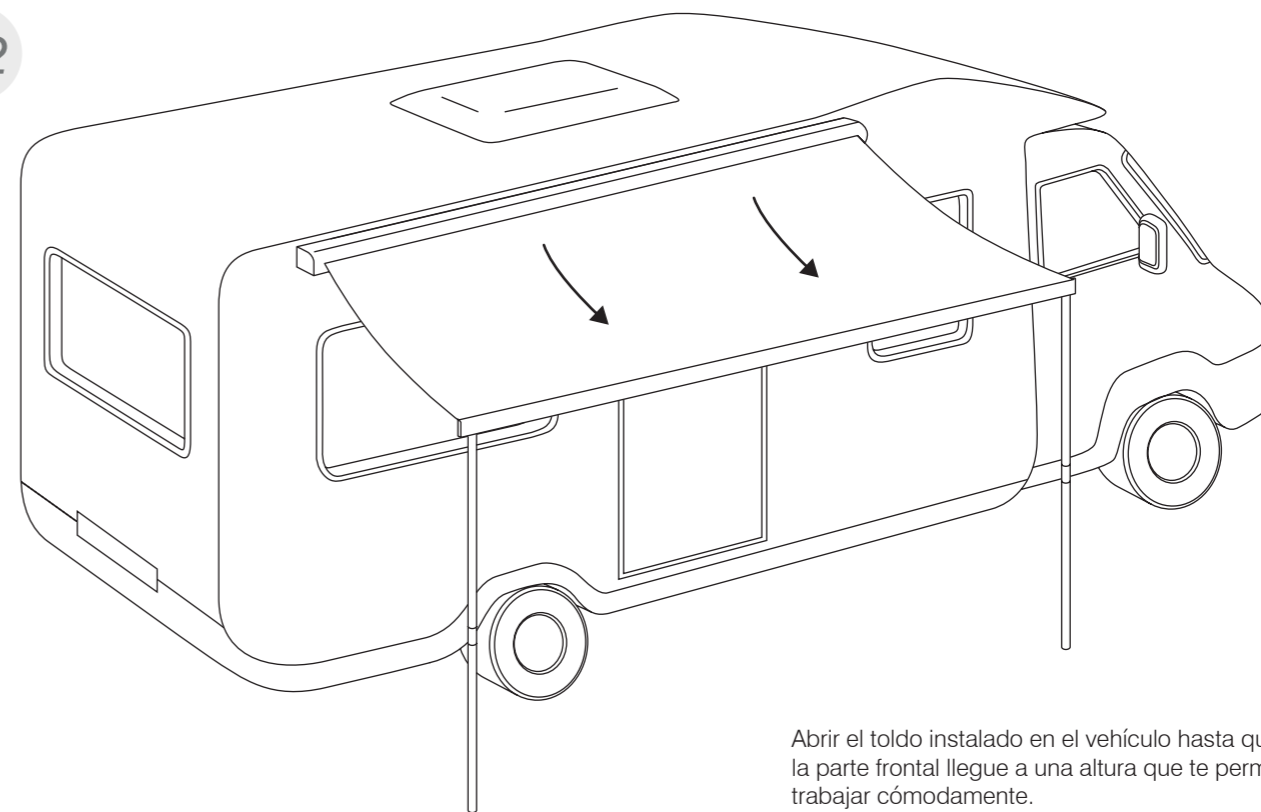

Abrir el toldo instalado en el vehículo hasta que la parte frontal llegue a una altura que te permita trabajar cómodamente.

Open the canopy installed on the motorhome until the height of the front part allows you to work easily.

#9

Opción toldo de techo/Caravana
Roof canopy/Caravan option

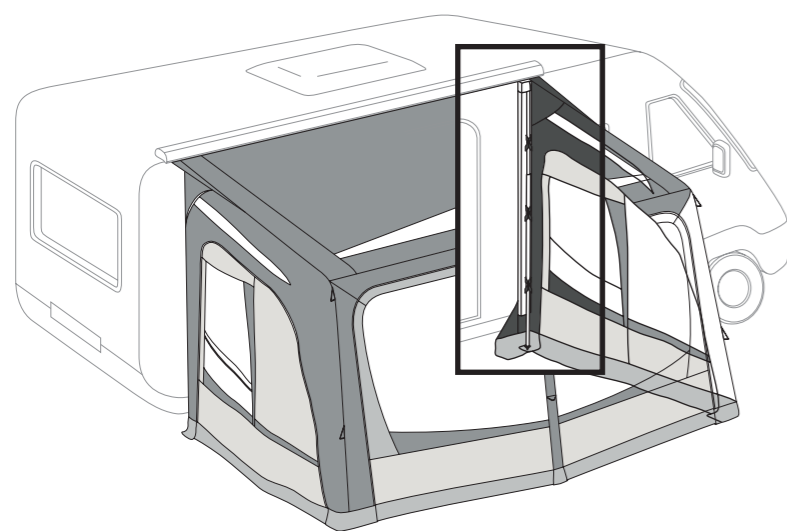

La pata trasera presiona la espuma lateral y se inserta dentro del bolsillo que la funda de esta espuma tiene en la parte superior.

The back pole push the side foam over the vehicle and gets into the foam cover pocket placed on the top.

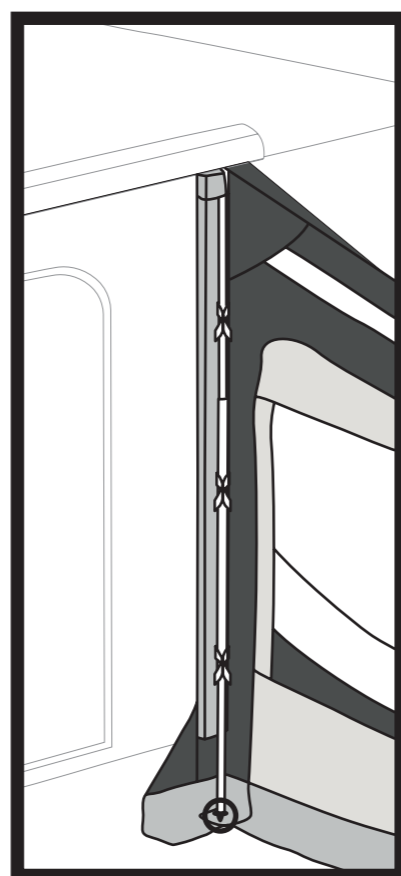

#3

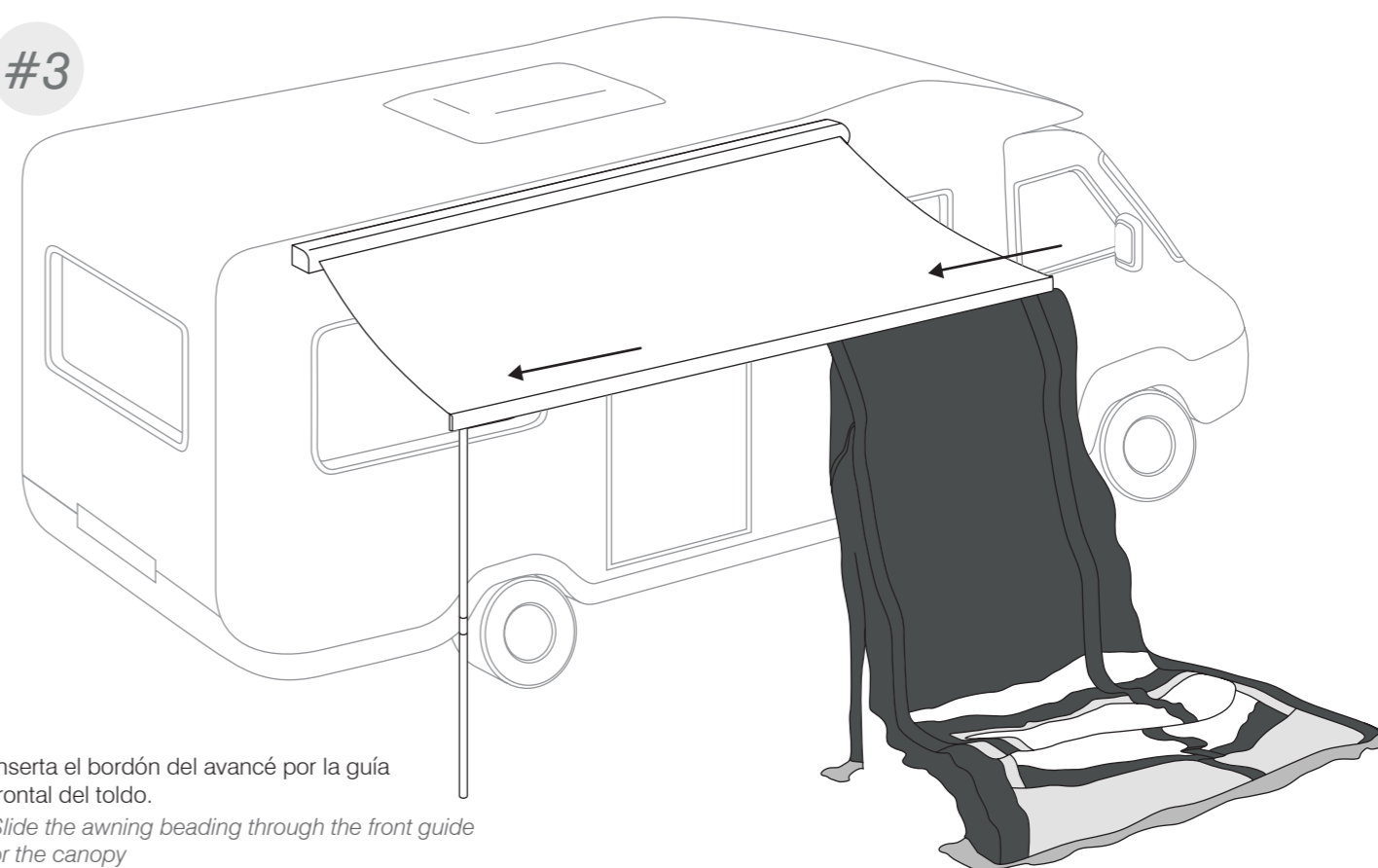

Inserta el bordón del avancé por la guía frontal del toldo.
Slide the awning beading through the front guide or the canopy

#4

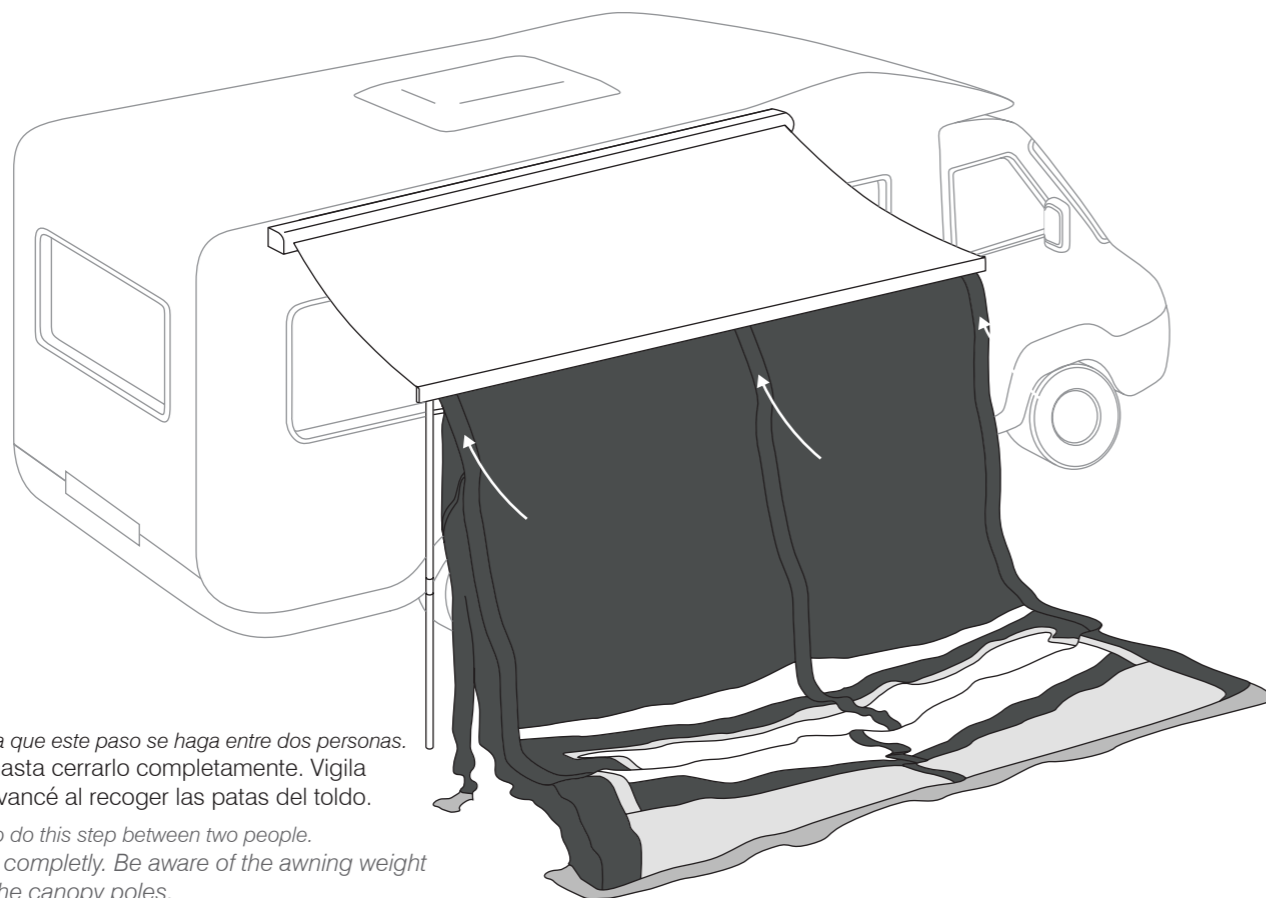

Inaca te recomienda que este paso se haga entre dos personas. Recoge el toldo hasta cerrarlo completamente. Vigila con el peso del avancé al recoger las patas del toldo.

Inaca advises you to do this step between two people. Close the canopy completely. Be aware of the awning weight while picking up the canopy poles.

#5

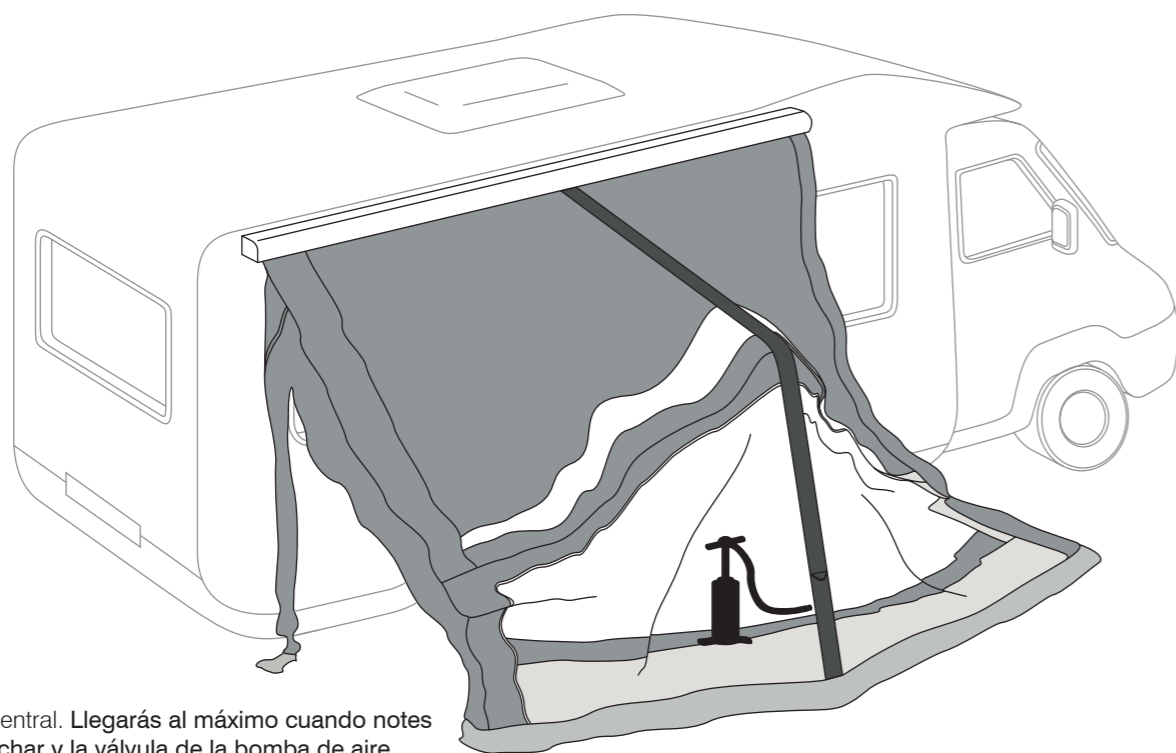

Infla la columna central. Llegarás al máximo cuando notes resistencias al hinchar y la válvula de la bomba de aire expulse el aire que intentas insuflar.

Inflate the central column. It will be at its maximum when becomes harder to pump it up and the air pump valve blow out the air you pumping in.

#6

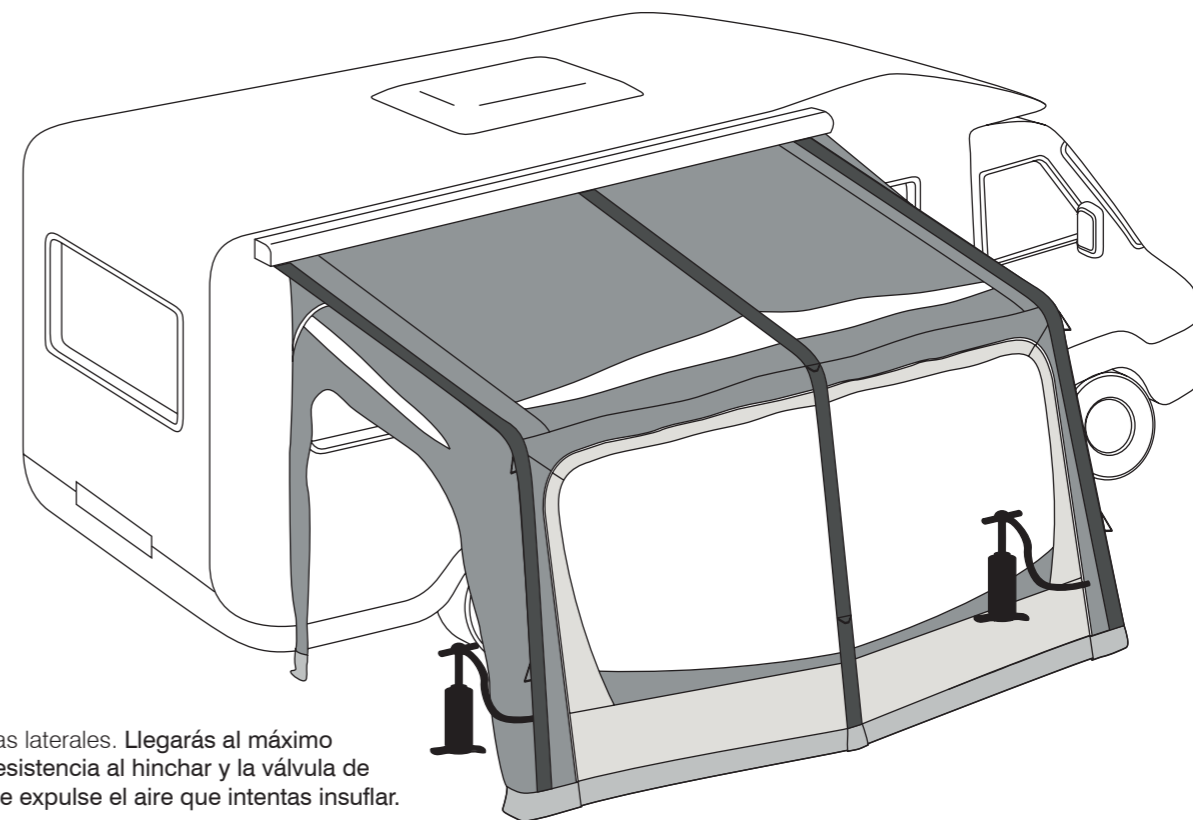

Infla las columnas laterales. Llegarás al máximo cuando notes resistencia al hinchar y la válvula de la bomba de aire expulse el aire que intentas insuflar.

Inflate the side columns. It will be at its maximum when becomes harder to pump it up and the air pump valve blow out the air you are pumping in.

#7

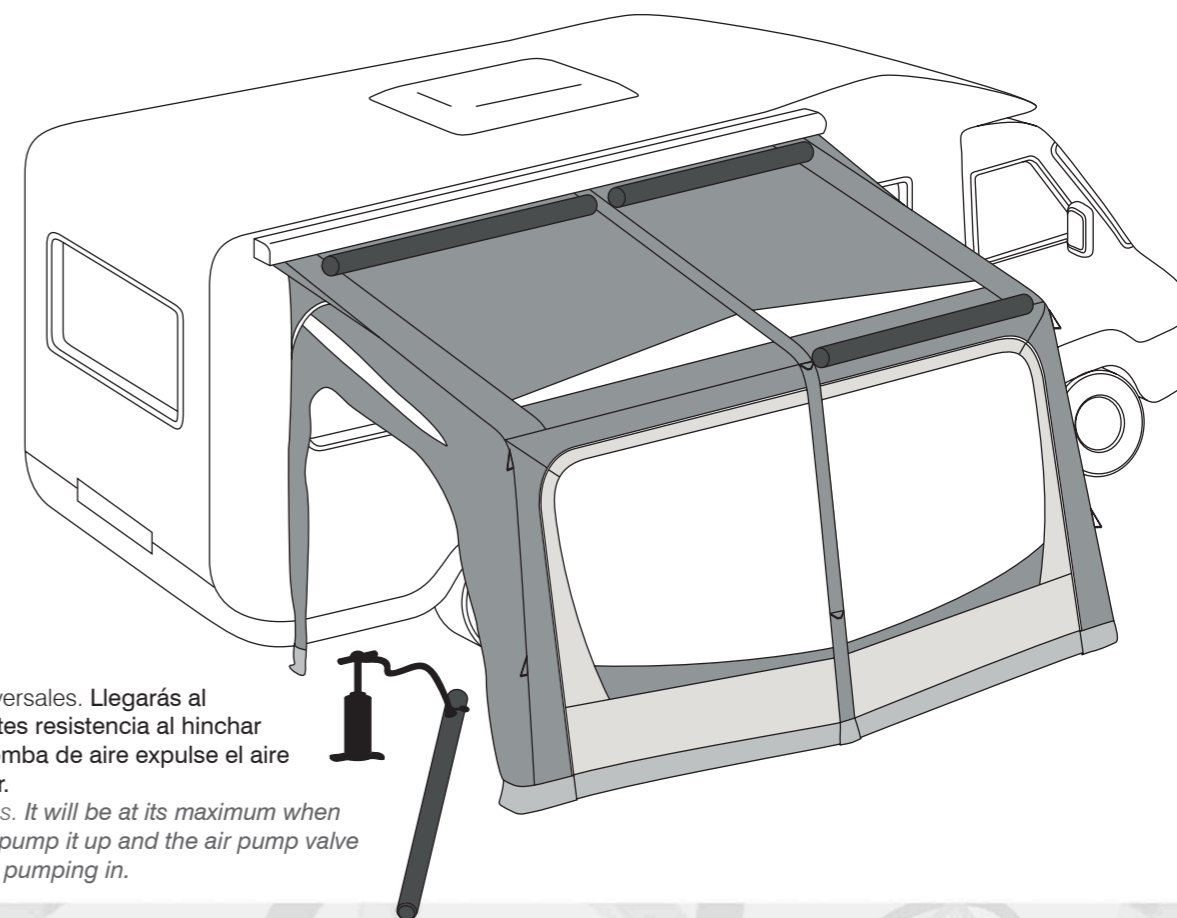

Infla los tubos transversales. Llegarás al máximo cuando notes resistencia al hinchar y la válvula de la bomba de aire expulse el aire que intentas insuflar.

Inflate the small tubes. It will be at its maximum when becomes harder to pump it up and the air pump valve blow out the air you pumping in.