

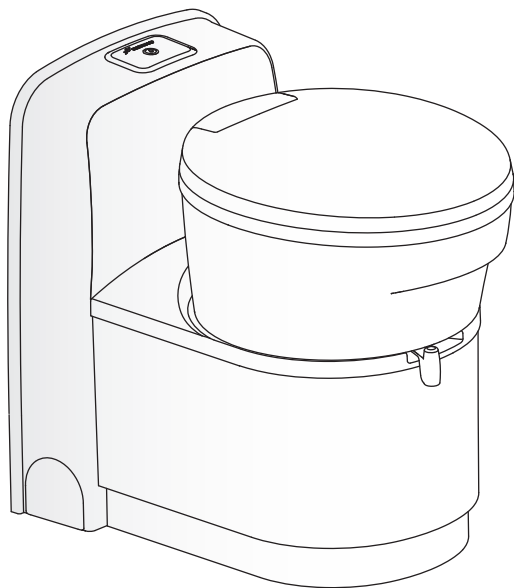

福莱康普

EN Cassette Toilet User & Installation Manuals 01



Model: W5000
适用型号: W5000

EN >>

Contents

User

Security considerations	02
Main components	03
Before use	04
Control panel logo & indicator	05
Toilet Use	05
Emptying the waste-holding tank	06

Routine Maintenance

Maintenance and cleaning	07
Winter use	08
When this product is left unused	08

Installation

Technical specifications	08
Installation dimensions	09
Accessories list	10
Service door installation	11
Installation	13
Connecting electricity	15
Install the vent hose & flange	17
Console removal	17

Others

Troubleshooting	20
Warranty regulations	21
Product Warranty Card	22





- Thank you for purchasing our products! Read this user manual carefully before you use the product and save it for future reference.

Security considerations

Please read this manual carefully before installation and install it in strict accordance with this manual. After reading, please keep this manual properly.

In order to avoid injury or property damage to users and others, please strictly observe the safety warnings and cautions.

- Symbols and meanings

	Warning! Risk of causing serious injury or damage.
	Caution! Not follow instruction will lead to damage.
	This symbol indicates that this operation is forbidden.
	This symbol indicates related information.

Warning

1. A lighted cigarette or other incendiary object must not be put into the toilet or it may cause a fire.
2. It is strictly prohibited to disassemble, repair or modify the product, otherwise it may cause personal injury or fire.
3. The product must be connected to DC12V electricity and the positive and negative poles of the electricity should be properly connected. Otherwise, the product may be damaged or cause a fire.

Caution

1. The seat and cover of this product have the function of slow down. Do not press hard to avoid damaging the decelerator.
2. When using this product, do not lean back on the cover to avoid damaging the product.
3. Do not pour newspaper, paper urinal pad, sanitary towel and the other clogging articles into the toilet.
4. Do not stand on the seat, cover or toilet.
5. Do not use the toilet below 0 °C. If the indoor temperature is lower than 0 °C, make sure you completely drain the waste-holding tank, to prevent it from expanding and freezing.
6. Make sure you cut off the electricity and close the water system of the vehicle during installation, disassembly and maintenance.
7. If you are not going to use this product for an extended period time, ensure that the power supply is off, and drain the waste-holding tank.
8. Children shall not play with this product.

Main components

Toilet

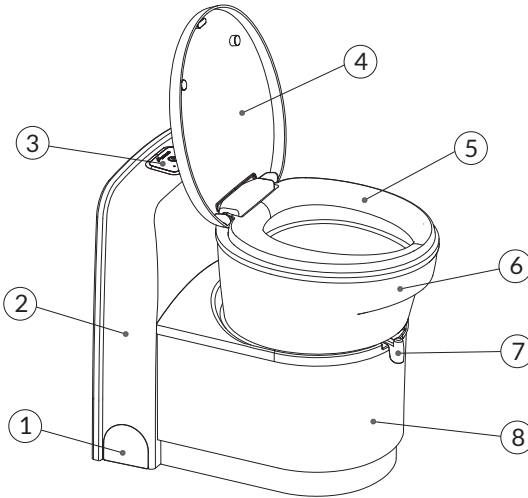

- ① Decorative pieces
- ② Console
- ③ Control panel
- ④ Cover
- ⑤ Seat
- ⑥ Swiveling toilet bowl
- ⑦ Blade handle
- ⑧ Bottom base

Waste-holding tank

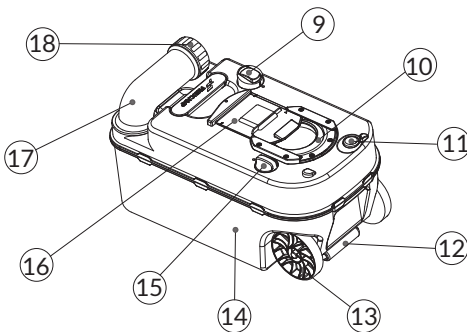

- ⑨ Automatic pressure release vent
- ⑩ Gasket
- ⑪ Vent button
- ⑫ Pull handle
- ⑬ Wheel
- ⑭ Tank
- ⑮ Blade opener
- ⑯ Sliding cover
- ⑰ Pour out spout
- ⑱ Cap

Before use

- Ensure that all packaging materials have been removed.

1. Remove the waste-holding tank through the service door.
2. Place the waste-holding tank upright and turn the pour out spout upwards. Remove the cap from the pour out spout.
3. Add the stated dosage cleaner to the waste-holding tank, and add 2L of water to the waste-holding tank to ensure that the bottom of the waste-holding tank is covered.

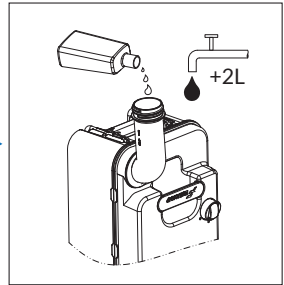
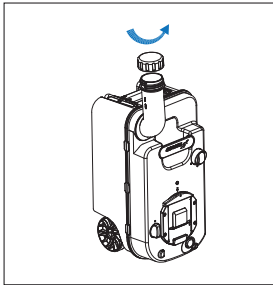
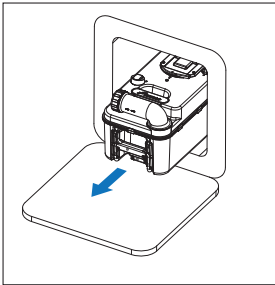

4. Screw the cap back onto the pour out spout. Slide the waste-holding tank back into its original position via the service door.

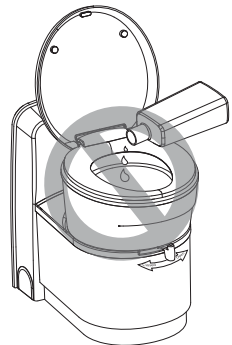
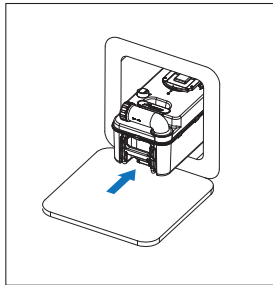
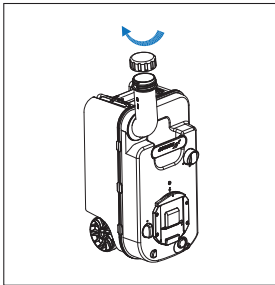

 Never add toilet cleaner directly via the valve blade or via the toilet bowl as this could damage the gasket ring of the waste-holding tank. Only fill the waste-holding tank via the pour out spout.

 Never use force if you cannot get the waste-holding tank back into place easily. If blockage occurs, always check if the blade closed position.

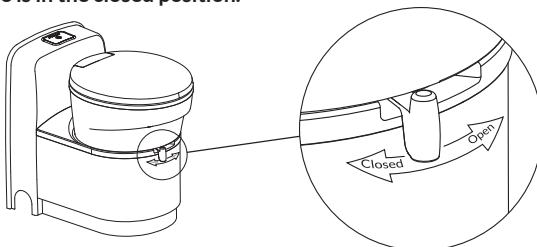

Control panel logo & indicator

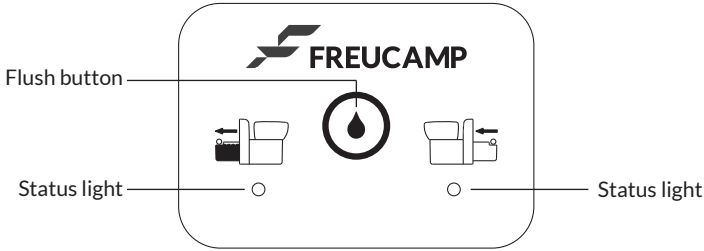

	Flush button: Press and hold it to flush the toilet. Release it to stop flushing.
	Light off: Indicates the holding tank is not full and it can be used normally.
	Flashing red light: Indicates the holding tank is full, need to empty it on time.
	Light off: Indicates the holding tank is in place and the blade handle is in the closed position. Meaning the toilet is closed.
	Solid green light: The blade handle is in the open position. Meaning the toilet is open.
	Flashing red light: The holding tank is removed or not in place. Meaning the toilet cannot be used.

Toilet Use

Use the toilet:

1. If wants to rotate the bowl to the desired position (max. 90° clockwise and 90°counterclockwise), use both hands to rotate the bowl.
2. Move the valve lever to "Open" to make it full-open (Right-hand light on the control panel indicates green).
3. Opening the Cover.



The toilet can withstand a maximum load of 125kg. Make sure you do not overload the toilet.

Flushing the toilet:

1. Make sure the blade is open (Righthand light on the control panel indicates green light).
2. Press the flush button and hold it for several seconds to flush the toilet.



Under special circumstances, such as the electric pulverizer is installed or the valve is closed for flushing, the free flushing mode can be entered after 12 times of continuous flushing within 5S. And repeat the above operation to exit this mode.

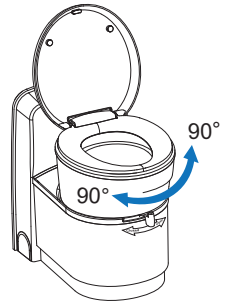

To prevent water leaking damaging your caravan, do not travel with water in the toilet bowl.



Close the blade if the toilet is not being used. Do not leave water in the toilet bowl.

Emptying the waste-holding tank

The waste-holding tank has liquid level indicator and water full alarm. When the left light on the control panel blinks red, you will hear a series of beeps by pressing the flushing button, it means the waste-holding tank is too full and must be emptied. When the alarm sound appears, the flushing button will stop after 5s delay. (If less than 5s, can be used up to 2 times).

Emptying the waste-holding tank:

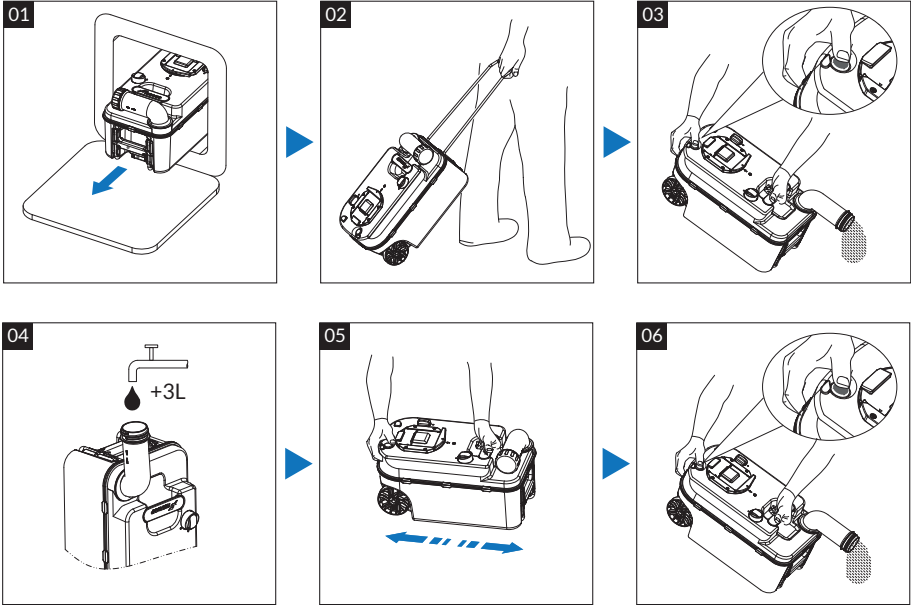

- If you want to continue using your toilet after emptying the waste-holding tank, prepare the waste-holding tank again. See Before use.



To prevent water leaking damaging your caravan, do not travel with a waste-holding tank that is more than 3/4 full.

Maintenance and cleaning

1. Freucamp recommends cleaning the toilet regularly to prevent scale.

- Please wipe the dirty area with a wrung-out soft cloth.



Never use household cleaners to clean the toilet. These may cause permanent damage to the gasket and the other components.



The blade gasket is a part of the toilet that is subjected to wear. Depending on the extent and manner of servicing, after a certain period the gasket will degrade and must be replaced.



Never use Vaseline or vegetable oil to lubricate the gasket. This may cause leakage to the waste-holding tank.



2. Freucamp recommends to remove the cover regularly to clean the dead corner.

- Press the button at the back of cover.
- Lift the cover and seat.
- Gently push forward to remove the seat and cover, and take down the cover components.

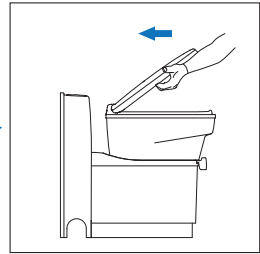
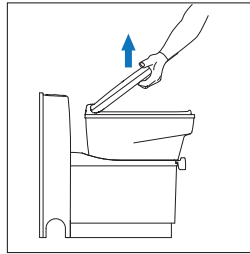
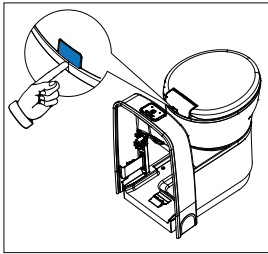

- Installation after removal: Align the cover with the fixed plate and insert it to complete installation.

3. How to use Freucamp cleaner.

- Daily use of Freucamp cleaner on the waste-holding tank to achieve the effect of degradation paper, sterilization and deodorization.



Unscrew the plastic cap directly, add 2 caps (100ml) and 2L of water into the waste-holding tank.

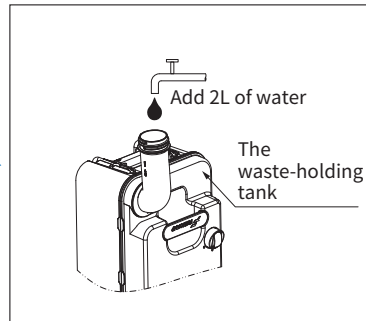
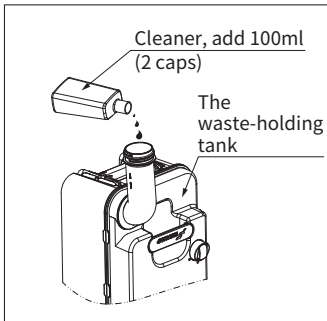

Winter use

1. The toilet seat can be used even in cold weather as long as it is placed in a heated area.

2. If there is no heating and there is a risk of frost, we recommend against using the toilet.

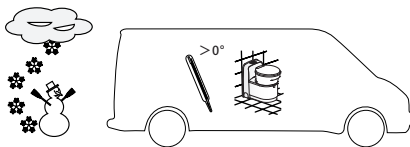

! If the indoor temperature is lower than 0 °C, be sure to complete the drain of the toilet and RV water system. Then empty the waste-holding tank, to prevent it from expanding and freezing.

When this product is left unused

1. Empty the water system of the vehicle.
2. Press and hold the flush button of the toilet until no water rushes out.
3. Empty and dry the waste-holding tank.
4. Rinse and dry the entire toilet thoroughly.
5. Slide the waste-holding tank back into its original position and close the blade.

Technical specifications

Model	W5000		
Direction	H	W	D
Dimensions(mm)	577	370	538
Net weight(kg)	8.3		
Capacity waste-holding tank (L)	17.2		

Installation dimensions

Unit: mm

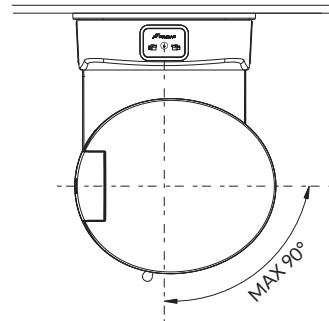
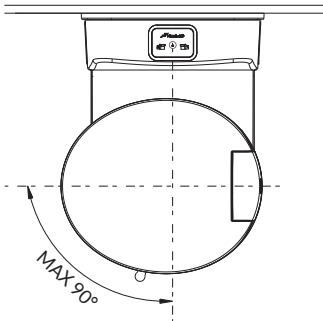
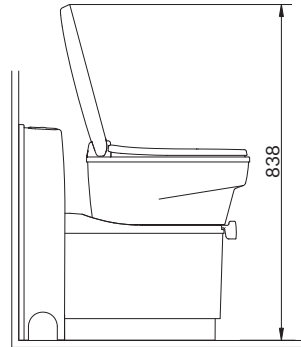
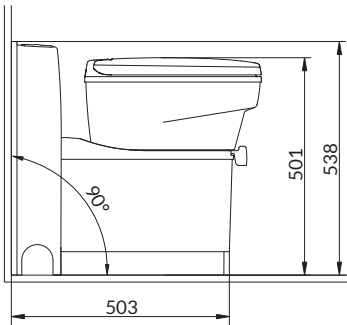
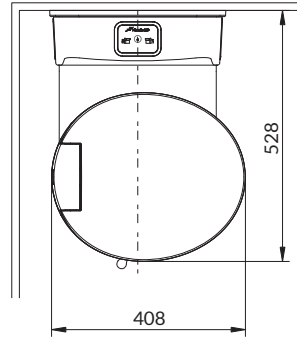
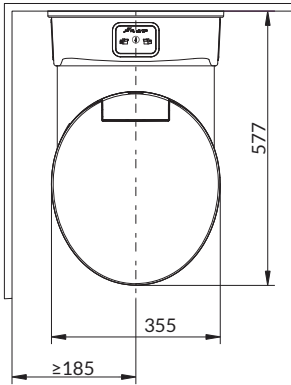

Accessories list

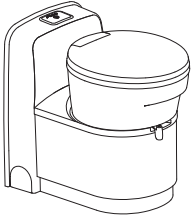

Toilet



3J-PHD-3# service door

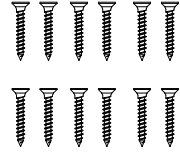

Screws ST3.5*25mm

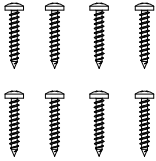

Screws ST4.2*25mm

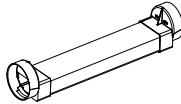

Square pipe

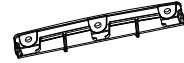

Wall bracket



Decorative pieces



Screws ST4.5*55mm



Screws ST4.2*13mm

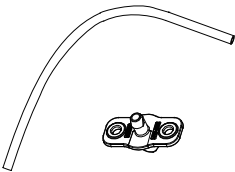

Vent hose & Flange

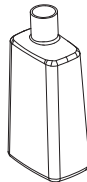

Degradation liquid

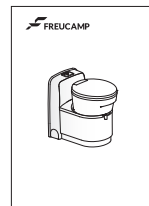

User Manual

Service door installation

1. Door dimensions.

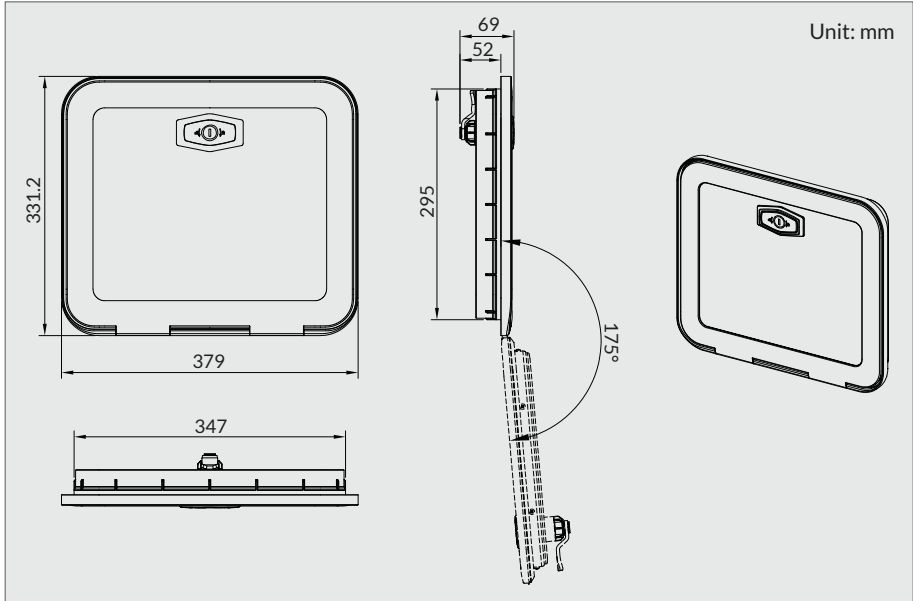

2. Opening position

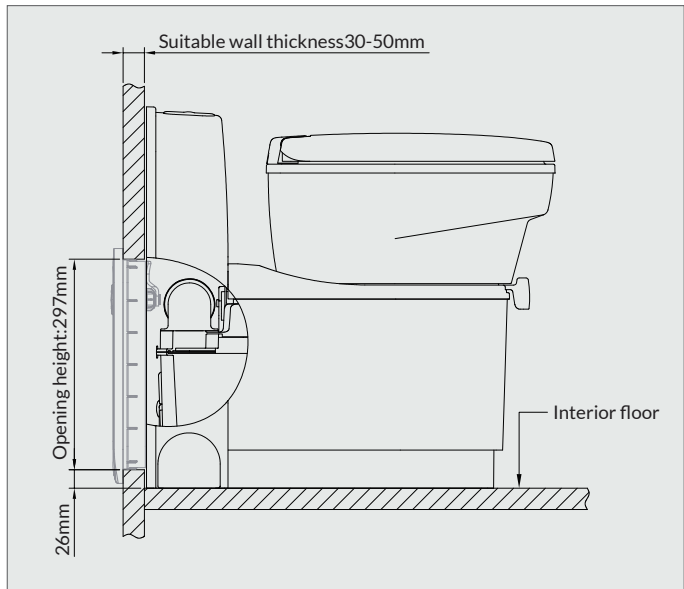

Service door installation

3. Service door installation.

- i** This product is only suitable for flat wall installation. And other special walls need to be treated flat before installation.
The four sides of the opening must be solid enough to bear the door installation strength.

• Installation steps:

Unit: mm

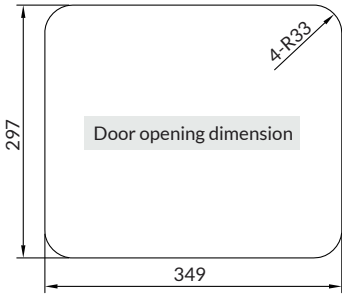
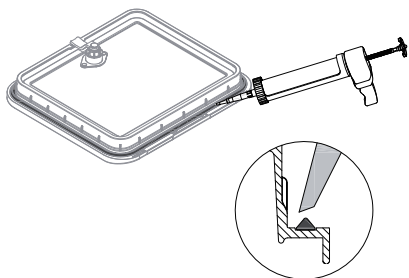
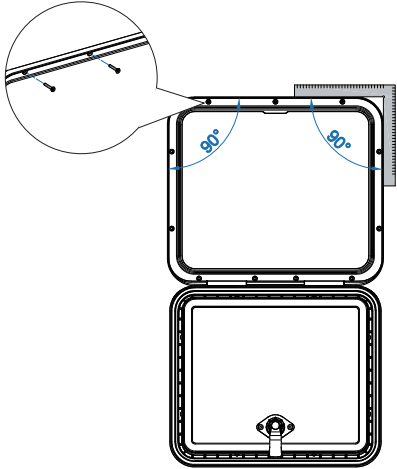
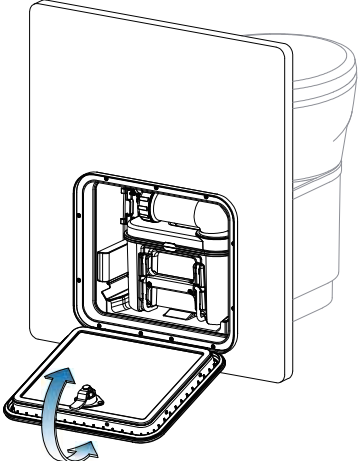
 <p>297</p> <p>349</p> <p>4-R33</p> <p>Door opening dimension</p>	
<p>1) Open the hole on the wall (the wall thickness needs to be between 30mm-50mm). Please refer to the opening position on the previous page.</p>	<p>2) Put the sealant into the groove of the outer ring of the door frame, which should not be too much. Please use a soft scraper to remove the spilled sealant.</p>
	
<p>3) Open the door and then install the glued door into the hole carefully. Fix the frame with screws in turn. Please check whether the four corners of the frame are perpendicular to each other before fixing.</p>	<p>4) Please check whether the cabin door is opened and closed smoothly, whether the adhesive tape is compressed after closing, and then check the appearance.</p>

- i** Screw installation torque: $1.2 \pm 0.3\text{N.M}$ (depending on the hardness of wallboard material).

Installation

1. Install the shower tray (if applicable).

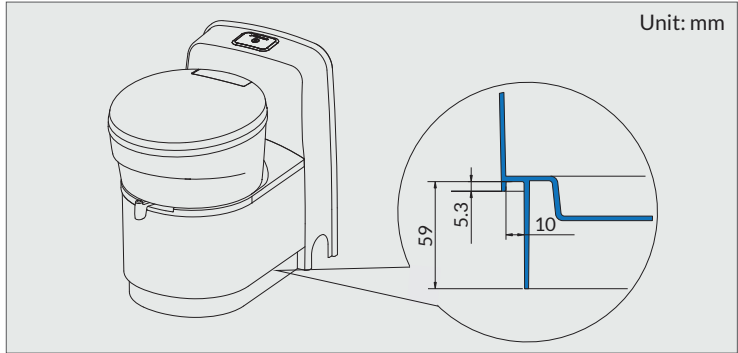

2. Mount the wall bracket to the outside wall with three screws ST4.2*13mm, connecting the toilet to the wall bracket.

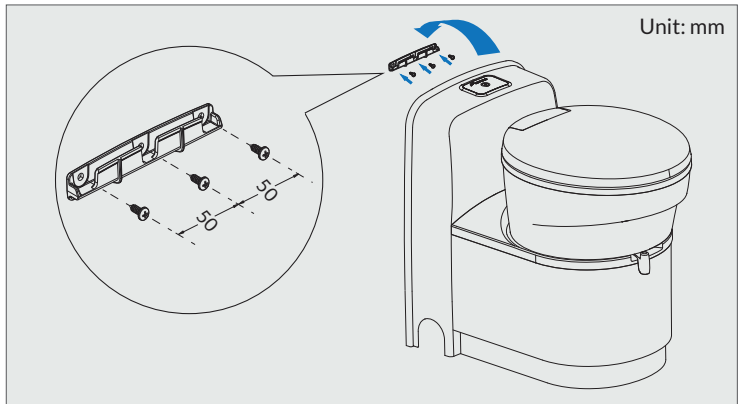

- i** Recommended distance between the wall bracket screws and the installation floor: 518mm (The actual installation may need to adjust the position appropriately).

Installation

3. Mount the toilet to the floor with four screws ST4.5*55mm.

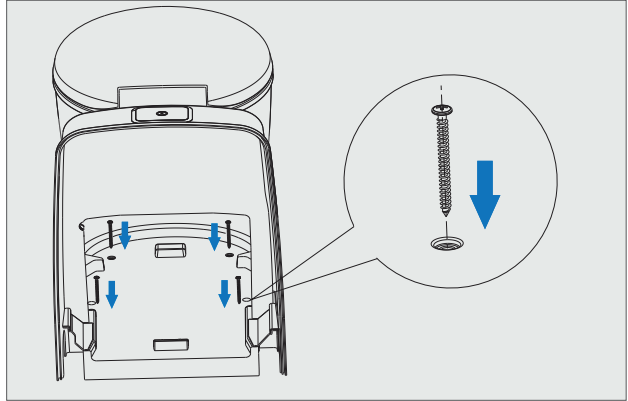

i Required torque (for a plywood floor): $1.2 \pm 0.3 \text{ N.m}$.
Torque may differ if the floor is made from a different material.

4. Connecting the water hose.
Length from the last fixed point: 300mm

Diameter	Inside: 10mm Outside: 16.5mm
Required pressure	Min.: 0.35bar at 4.2L/min Max.: 0.70bar at 7.1L/min
Maximum allowable pressure	8bar

i Make sure after the hose is connected, the waste-holding tank can still be pulled out of the toilet seat and removed.

Installation

5. Adjust flush pressure (if applicable).

Meet the required pressure for the remote pump at the toilet inlet to ensure correct flush.

If the pressure is too high, use a slotted screwdriver to adjust the “water pressure control” knob on the solenoid valve.

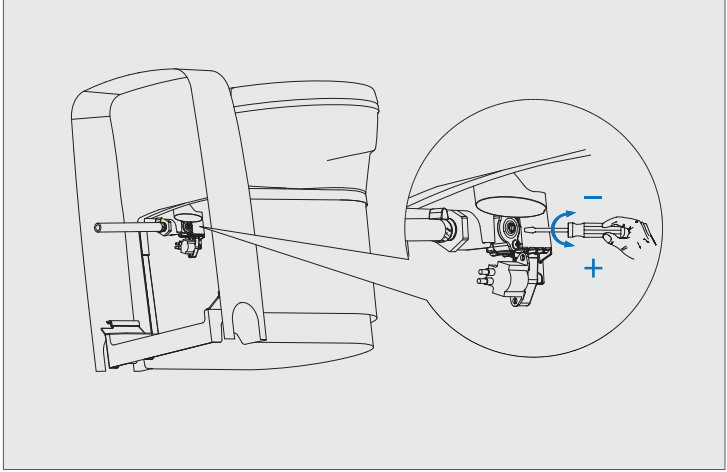

Connecting electricity

1. Length of main cord.

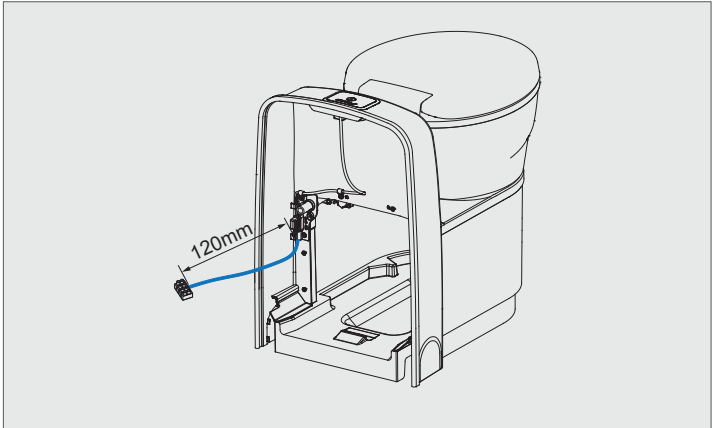

Connecting electricity

2. Use the following parameters to connect the power supply correctly.

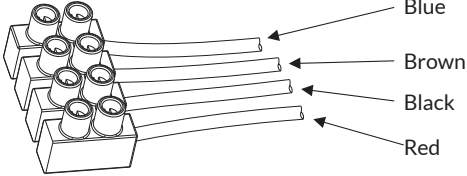
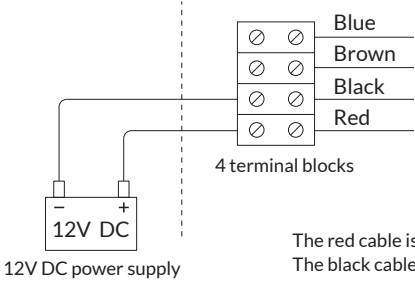
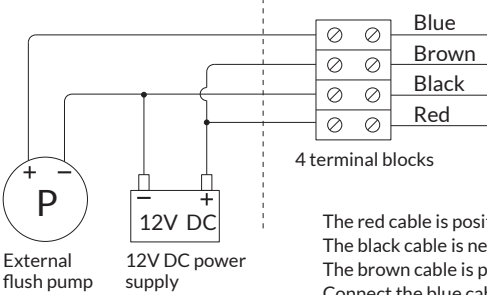
Connector	4 terminal blocks
Position wiring	
Cable connections when the toilet is connected to a pressure system	 <p>12V DC power supply</p> <p>4 terminal blocks</p> <p>The red cable is positive. The black cable is negative.</p>
Cable connections when the toilet is connected to a non-pressure system	 <p>External flush pump</p> <p>12V DC power supply</p> <p>4 terminal blocks</p> <p>The red cable is positive. The black cable is negative. The brown cable is positive. Connect the blue cable to the positive connection of the pump.</p>

⚠ The power supply specifications: 12V DC.

Install the vent hose & flange

Insert the vent hose through the limit hole on the fuse pressing plate, and then into the support frame joint, connect the vent joint at the other end. Drill a 9mm hole at a suitable position on the vehicle ground or side wall, and fix the vent joint on the hole with two ST4.2*13mm self-tapping screws.

- i** The installation should avoid to affect the loading and unloading of tank.

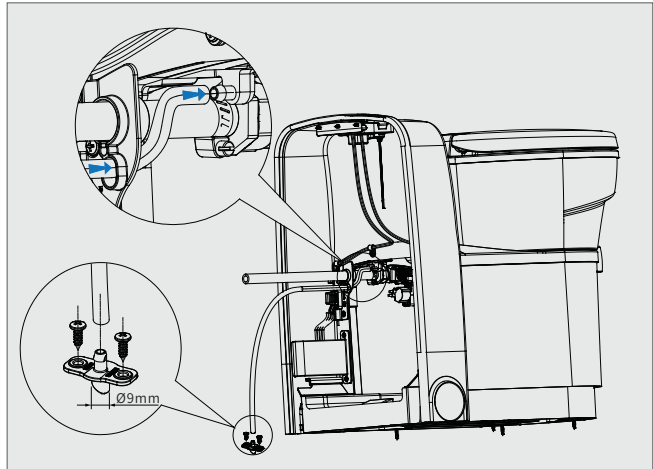

Console removal

- Remove the W5000 console as follows:

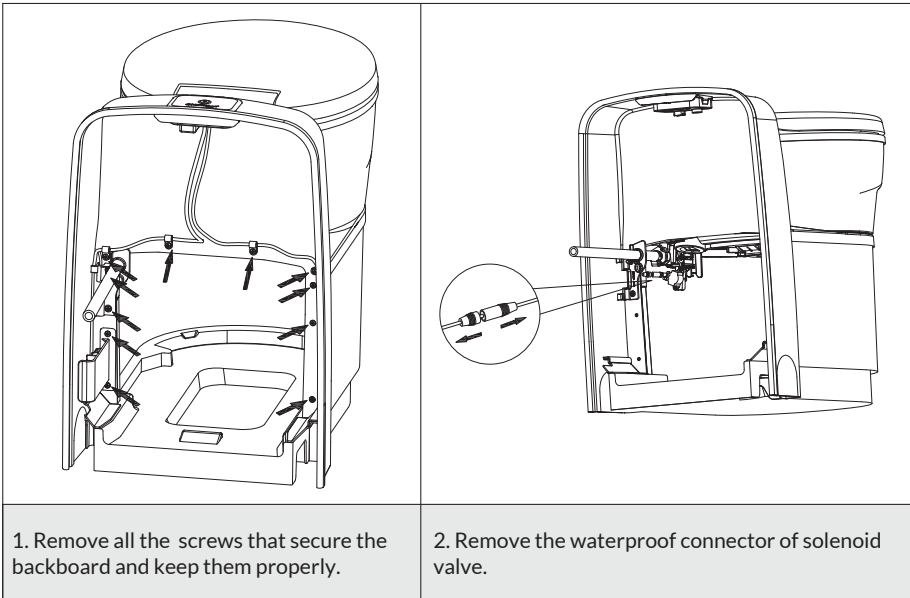

Console removal

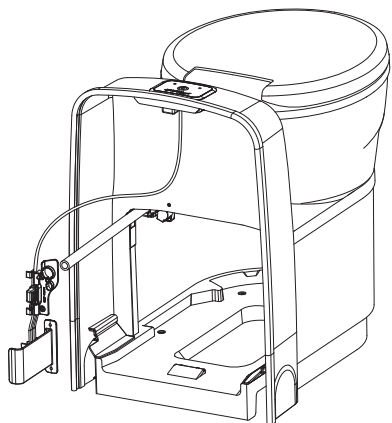

3. Remove the fuse bracket and side cover.

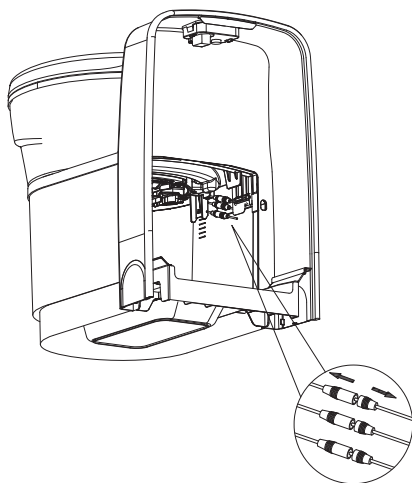

4. Remove the three waterproof joints as shown in the figure.

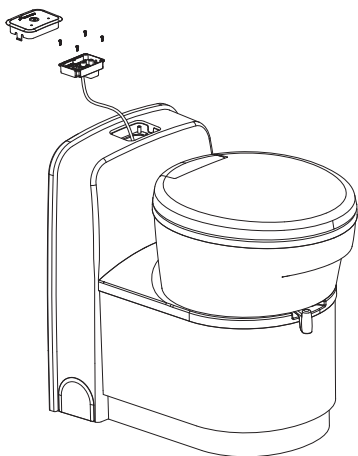

5. Remove the control panel and control box

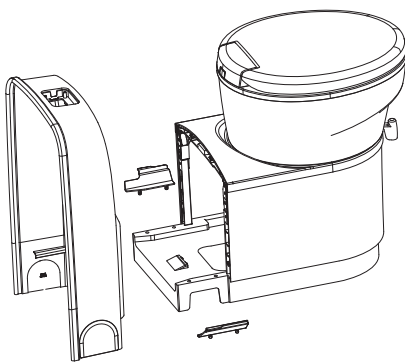

6. Remove the console and fixing plates on the left and right.

Console removal

Lock the four screws according to the position shown in the figure, and the screw torque is less than or equal to 1.2N.m.

Suggested size of opening hole in control box.
Length: 88 ± 1 mm.
Width: 62 ± 1 mm.
Depth: ≥ 43 mm.

Install the control board on the control box, and inject proper amount of glue into the four corners. After glue is applied, make sure that the function keys are normal

7. Re-connect the solenoid valve connector. Use 4 screws to lock according to the position shown in the figure, and the screw torque is less than or equal to 1.2N.m.

8. Re-connect the three waterproof joints, pay attention to distinguish the joint color. And fix the main control board with glue. Open holes in suitable mounting locations for control box installation.

9. Re-install the control box and control board at the appropriate position, and then test whether the function is normal.

Troubleshooting

Malfunctions	Possible reasons	Solutions
Unable to pull out the waste-holding tank	<ol style="list-style-type: none"> 1. Blade (partially) not closed 2. Due to the clip of waste-holding tank not lifted 	<ol style="list-style-type: none"> 1. Fully close the blade 2. Lift the clip, then pull out
Press the flush button but no flush-water	<ol style="list-style-type: none"> 1. When the waste-holding tank is full, the left light on the control panel blinks red 2. When the waste-holding tank is removed or not in place, the right light on the control panel blinks red 3. When the blade is closed, the light on the control panel is off 4. When the light on the control panel is off, indicates the toilet fuse is blown out 	<ol style="list-style-type: none"> 1. Empty the waste-holding tank 2. Slide the waste-holding tank back in place 3. Move the blade handle to open the blade 4. Replace the toilet fuse
Waste-holding tank leaking	Gasket is dry or worn out	Replace gasket
Unpleasant smells	<ol style="list-style-type: none"> 1. Blade is (partially) open after use 2. Not using Freucamp cleaner 	<ol style="list-style-type: none"> 1. Close the blade after use 2. Use Freucamp cleaner



In order to flush, please turn the blade handle to make it open.
 After using, please close the blade handle.
 Do not use the toilet when the red light is flashing.



If you cannot solve the problem, contact the authorized local service center or Freucamp Customer Service Office in your country.

Warranty regulations

1. The whole machine of this product is guaranteed free of charge for one year.
2. During the warranty period, the fault caused by normal use in accordance with the instructions (determined by the official staff of the company) will be repaired free of charge.
3. During the warranty period, in case of any of the following circumstances, a charge repair and lifetime service will be implemented:
 - 1) Unable to provide this warranty card and valid purchase certificate.
 - 2) Invoice alteration.
 - 3) Failure and damage caused by unexpected factors and improper use.
 - 4) Failure damage caused by self-repair without permission of our company.
 - 5) Damage caused by using power supply and voltage other than specified.
 - 6) Products that continue to be used after the expiry of three guarantees after repair.
4. Only the above warranties are made without any other warranties, express or implied, including the implied warranties of merchantability, rationality and adaptability for a particular application). The company shall not be liable for any special, incidental or indirect damages, whether in contract, in civil negligence or otherwise.
5. The period of validity of the three guarantees is calculated from the date of invoice, excluding the time occupied by repair and waiting for repair without spare parts. During this period, the consumer shall handle the repair, return and replacement with the invoice and Three Guarantees certificate.
6. The consumer can choose to return, exchange or repair the product in case of performance failure within 7 days from the date of sale.
7. If the product fails within 15 days from the date of sale, the consumer can choose to replace or repair it.

Follow-up calls: 400-839-8111

Product Warranty Card

Product name: _____

Product style: _____

Factory number: _____

Manufacture Date: _____

Customer name: _____ Phone: _____

Customer address: _____



Warranty contents: _____

Customer Service Executive: _____

Customer signature: _____ Satisfied Dissatisfied



Warranty contents: _____

Customer Service Executive: _____

Customer signature: _____ Satisfied Dissatisfied



Warranty contents: _____

Customer Service Executive: _____

Customer signature: _____ Satisfied Dissatisfied





福莱康普

乔尼克责任有限公司

Joniq GmbH

邮编 (P.C) : 40549 电话 (TEL) : 4008398111

地址 (ADD) : 德国杜塞尔多夫赫尔特兰德大街 189F

Heerdter Landstraße 189F, Düsseldorf, Deutschland

- 由于产品改进，本说明中产品图片有可能与产品实物不完全相符，因此产品外观和颜色以实物为准。
- The images of the product may be slightly different from the material objects due to the continuous research and improvement efforts.

ASWFCC0429000A-1.3