

Ultrastore Rapid GE

GB **Operating instructions**
Installation instructions

To be kept in the vehicle!

Page 3

Page 9

Showering with the Ultrastore Rapid GE

The Truma Ultrastore Rapid GE has 10 litre capacity. It is more than capable of heating enough water to give out three consecutive hot showers.

When using the boiler, you should observe the following points to achieve this:

- Switch the Ultrastore on 16 minutes before required use.
- Switch on dual power mode (gas and electricity),
Gas operation – 70 °C / electric operation – 1300 W
- Set the mixing tap in the shower to approx. 38 °C and maintain a medium flow rate (approx 2.5 l / minute) when in the shower
- Switch off the water when applying shampoo / shower gel etc.
- Do **not** switch the Ultrastore off when showering

As long as the Ultrastore remains in operation, other people can shower as the water is continually reheated.

Example: Sufficient warm water capacity for three consecutive hot showers



Water temperature 38 °C
Water flow rate 2.5 l / minute
Water consumption per person 12.5 l



Switch off the water when applying shampoo / shower gel.

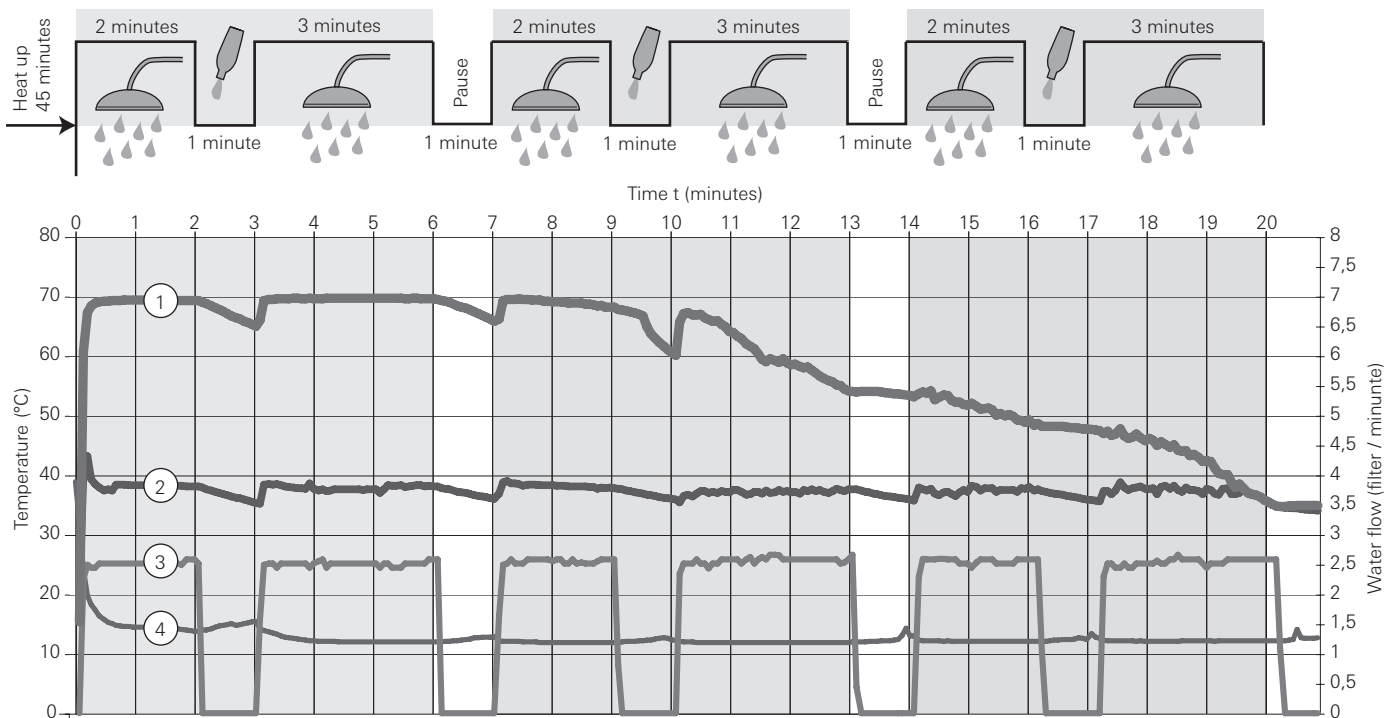

① Warm water (Ultrastore) temperature

② Mixed temperature tap

③ Water flow

④ Cold water temperature

Table of contents

Symbols used	3
Safety instructions	4
Important operating notes	4

Operating instructions

Filling the Truma Ultrastore with water	5
Draining the water heater	5
Switching on Gas operation	5
Switching off	5
Red LED "Failure"	5
Switching on Electric operation	5
Maintenance	6
Fuses	6
Disposal	6
Technical data	6
Trouble-shooting list	7
Declaration of conformity	8
Manufacturer's terms of warranty	8

Installation instructions

Intended use	9
Regulations	9
Water heater kit	9
Choice of location	9
Installation of the water heater	9
Water connection	10
John Guest System rigid pipe routing	10
Flexible water hose routing	11
Installation of the safety (pressure relief) drain valve	11
Water pipe routing	11
Gas connection	11
Installation of the control panels	12
Electrical connection 12 V	12
Electrical connection 230 V	13
Connection 230 V control panel	13
Function check	13
Warning information	13
Accessories	14

Symbols used



Symbol indicates a possible hazard.



Comment including information and tips.

Safety instructions

The use of upright gas cylinders from which gas is **taken in the gas phase** is mandatory for the operation of gas regulators, gas equipment and gas systems. Gas cylinders from which gas is taken in the liquid phase (e.g. for fork lifts) must not be used, since they would result in damage to the gas system.

In event of leaks in the gas system or if there is a smell of gas:

- extinguish all naked flames
- do not smoke
- switch off all appliances
- shut off the gas cylinder
- open the windows and doors
- do not actuate any electrical switches
- have the entire system checked by an expert!



Repairs may only be carried out by an expert.

During use, please observe the regulations of EN 60335-1:2010, according to which this device has not been designed for use by people (including children) who have restricted physical, sensory or mental abilities or a lack of experience and / or knowledge, unless they are supervised by a person responsible for their safety or have received instructions from that person as to how the device is to be used.

Children should be supervised to ensure they do not play with the device.



To avoid risk caused by unintentional resetting of the overtemperature sensor, the device may not be supplied via an external switching device, such as a timer, or be connected with a circuit that is regularly switched on and off by any kind of equipment.

Guarantee claims, warranty claims and acceptance of liability will be ruled out in the event of the following:

- modifications to the unit (including accessories),
- modifications to the exhaust duct and the cowl,
- failure to use original Truma parts as replacement parts and accessories,
- failure to follow the installation and operating instructions.

It also becomes illegal to use the appliance, and in some countries this even makes it illegal to use the vehicle.

The operating pressure for the gas supply (30 mbar) must correspond to the operating pressure of the appliance (see data plate).

Liquid gas systems must accord with the technical and administrative regulations of the particular country in which they are being used (e.g. EN 1949 for vehicles). National regulations must be respected.

The testing of the gas system must be repeated **every two years** by a qualified specialist and, if appropriate, confirmed on the inspection certificate.

The vehicle owner is always responsible for arranging the inspection.

Liquid gas equipment must not be used when refuelling, in multi-storey car parks, in garages or on ferries.

During the initial operation of a brand new appliance (or after it has not been used for some time), a slight amount of fumes and a slight smell may be noticed for a short while. Remedial action here is to immediately run the heater and to ensure adequate room ventilation.

If the burner makes an unusual noise or if the flame lifts off, it is likely that the gas pressure regulator is faulty and it is essential to have it checked.

Items sensitive to heat (e.g. spray cans) must not be stored in the installation area, since excess temperatures may under circumstances be incurred there.

Only pressure control equipment that complies with EN 12864 (in vehicles) with a fixed delivery pressure of 30 mbar must be used for the gas system. The flow rate of the pressure control device must correspond to at least the maximum consumption of all devices installed by the system manufacturer.

Important operating notes

If the cowl has been placed near or directly beneath an opening window, the device must be equipped with an automatic shut-off device in order to prevent operation with the window open.

Always mount the cowl cap if the water heater is not being used. Non-observance of this point can lead to the function of the appliance being impaired through water, dirt or insects.

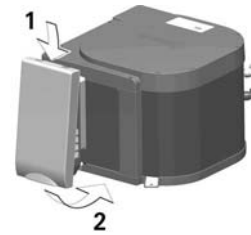

Before setting off on any journey, fit cowl cap with the boiler switched off. Please ensure that it is secure and has locked into place (risk of accident). Defective cowl caps must not be used.

There shall be no claim under guarantee if this point is not observed. Always remove the cowl cap prior to operating the water heater!

If just the cold water system is being used, without water heater, the heater tank is also filled up with water. In order to avoid damage through frost, the water contents must be drained by actuating the safety/drain valve, also when the heater has not been used. As an alternative, two shut-off valves, resistant to hot water, can be fitted in front of the cold and hot water connection.

Drain the water heater if there is a risk of frost! There shall be no claim under guarantee if this point is not observed.

If connecting to a central water supply (rural or city connection) or when using more powerful pumps, a pressure reducer must be used which prevents pressures of greater than 2.8 bar occurring in the Ultrastore.

Operating instructions

Always observe the operating instructions prior to starting! The vehicle owner is responsible for the correct operation of the appliance.

The installer or vehicle owner must apply the yellow sticker with the warning information, which is enclosed with the appliance, to a place in the vehicle where it is clearly visible to all users (e.g. on the wardrobe door)! Ask Truma to send you stickers, if necessary.

! Before using the first time, it is essential to flush the entire water supply through with clean warm water. Always mount the cowl cap when the water heater is not being operated! Drain the water heater if there is a risk of frost! **There shall be no claims under guarantee for damage caused by frost!**

Materials in the device which come into contact with water are suitable for use with drinking water (see manufacturer declaration: www.truma.com – Manufacturer Declaration).

Filling the Truma Ultrastore with water

Check that the safety/drain valve in the cold water intake is closed: Lever should be in horizontal position, position (e).

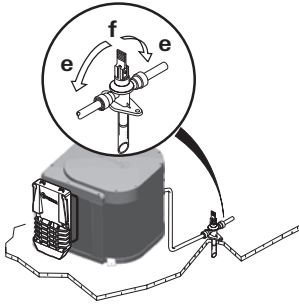

e = Lever position "Closed"
f = Lever position "Drain"

Open hot tap in bathroom or kitchen, with pre-selecting mixing taps or single-lever fittings set to "hot".

Switch on power for water pump (main switch or pump switch).

Leave the tap open to let air escape while the water heater is filling. The heater is filled when water flows out of the tap.

Residues of frozen water can prevent filling if there is a frost. The water heater can be defrosted by switching on the heater for a short period (max. 2 minutes). Frozen pipes can be defrosted by heating the room.

Draining the water heater

! If the mobile home is not used during periods of frost, it is essential that the Truma Ultrastore be emptied.

Disconnect power for water pump (main switch or pump switch).

Open hot water taps in bathroom and kitchen.

Open safety/drain valve: Lever in vertical position, position (f).

The water heater is now drained directly to the outside via the safety/drain valve. Check that the water contents have been completely drained (10 litres).

Switching on Gas operation

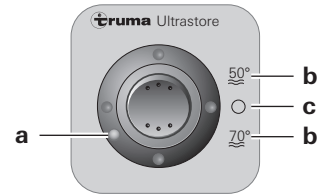

a = Red LED "Failure"
b = Water heater "On" 50 °C or 70 °C
c = Water heater "Off"

! Never operate the water heater without water in it!

If the cowl is positioned vertically below an opening part of a window, the water heater must be fitted with an automatic shut-off device to prevent operation when the window is open.

Remove cowl cover.

Open gas cylinder and open quick-acting valve in the gas supply line.

Switch on water heater at the switch on the control panel (b).

When using the vehicle switches: refer to operating instructions of the vehicle manufacturer or see switch labels.

If there is air in the gas supply line, it may take up to a minute before the gas is available for combustion. If the appliance switches to "Failure" during this period, switch off the appliance – wait 5 minutes – and switch on again!

Switching off

Switch off the water heater (c). Mount cowl cap. Drain the water heater if there is a risk of frost. Close quick-acting valve in the gas supply line if the appliance is not to be used for a longer period of time and close the gas cylinder.

Red LED "Failure"

The red LED (a) lights up if there is a failure. For possible causes please refer to page 7. To unlock, switch off the appliance, wait 5 minutes, and switch on again.

Switching on Electric operation

(230 V ~, 850 W, 3.7 A / 1300 W, 5.7 A)

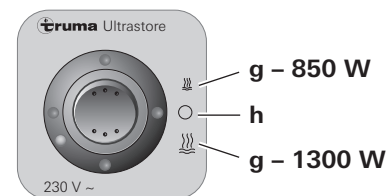

g = Water heater "On" 850 W or 1300 W
h = Water heater "Off"

Never operate the water heater without water in it!

Switch on at the control panel (g).

When using the vehicle switches: refer to operating instructions of the vehicle manufacturer or see switch labels.

! The water temperature cannot be selected, automatic temperature limitation at approx. 70 °C! For a faster heating up period the appliance can be simultaneously operated with gas **and** electrical power.

i The electrical heating element is equipped with an over-temperature sensor. In the event of a fault, switch off at the operating element. Check water content, refill if required (close drain valve). Wait 10 minutes, then switch on again.

Maintenance

We recommend to use twice a year the Truma system care set for cleaning, disinfecting and looking after the boiler. Other products – in particular products containing chlorine – are unsuitable.

To avoid infestation by micro-organisms, the water content must be heated to 70 °C at regular intervals.

Clean the device and the ventilation slits with a dry and fluff-free cloth.

Fuses

The water heater 12 V fuse is on the electronic control unit on the water heater.

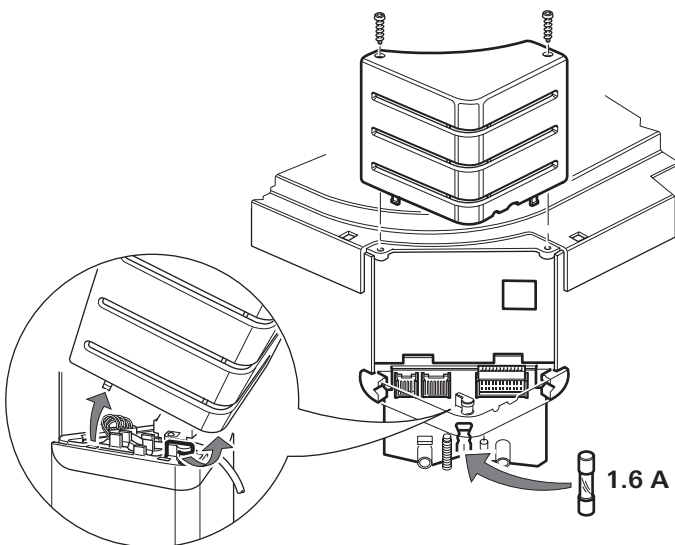

i Only replace the miniature Fuse on the p.c.b. with a fuse of the same type: 1.6 A, EN 60127-2-3 (slow action).

If there is a defect in the electronics, return the control p.c.b. well padded. If you fail to pack it correctly the guarantee shall no longer be valid.

Only use original Truma Ultrastore control p.c.b.'s as spare parts!

Disposal

The device must be disposed of in line with the administrative regulations of the respective country in which it is used. National regulations and laws (in Germany, for example, the End-of-life Vehicle Regulation) must be observed.

Technical data

Determined in accordance with EN 15033 or Truma test conditions.

Manufacturer

Truma Gerätetechnik GmbH & Co. KG
P.O. Box 1252
85637 Putzbrunn (Munich)
Germany

Water contents

10 litres

Pump pressure

max. 2.8 bar

System pressure

max. 4.5 bar

Type of gas

Liquid gas (propane / butane)

Operating pressure

30 mbar

Rated thermal output

1500 W

Gas consumption

120 g/h

Heating up time from approx. 15 °C to approx. 70 °C

Rapid GE – 10 litres

Gas operation: approx. 31 min.

Electrical operation: approx. 29 min.

Gas and electrical operation: approx. 16 min.

Power consumption 12 V

Ignition: 0.17 A

Heating up: 0.08 A

Standby: 0.04 A

Power consumption 230 V

Heating up: (3.7 A) 850 W / (5.7 A) 1300 W

Stand-by Consumption Gas

approx. 70 W

Weight (empty)

approx. 7.2 kg

CE 0085

The right to effect technical modifications is reserved!

Dimensions

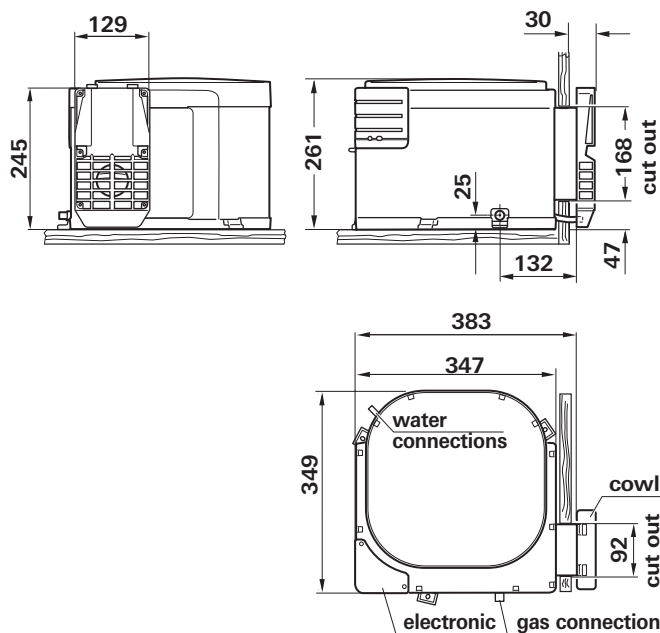

All dimensions in mm.

Trouble-shooting list

Fault	Cause	Rectification
Gas operation		
When switching on, the heater does not operate.	<ul style="list-style-type: none">– No 12 V supply voltage.– Window open.	<ul style="list-style-type: none">– Check the power supply (operation voltage min. 10.5 V).– Check the water heater fuse (refer to maintenance "Fuses").– Close any windows above the cowl.
When switching on, the heater does not operate and the red lamp lights up after approx. 30 secs.	<ul style="list-style-type: none">– Cowl cover fitted.– No gas supply.– Incorrect gas pressure.– Air in the gas supply.	<ul style="list-style-type: none">– Remove cowl cover and / or clear any obstruction.– Check gas valves and gas bottle.– Check gas valves and gas bottle.– To unlock (and purge air), switch off the appliance, wait 5 minutes, and switch on again.
Heater operates for a prolonged time and then the red lamp lights up.	<ul style="list-style-type: none">– Over temperature sensor has responded.	<ul style="list-style-type: none">– Check water content, refill if required (close drain valve).– To unlock, switch off the appliance, wait 5 minutes, and switch on again.
Electrical operation		
When switching on, the heater does not operate.	<ul style="list-style-type: none">– No 230 V supply voltage.– Over temperature sensor has responded.– Too slow warm-up in position 850 W.	<ul style="list-style-type: none">– Connect the caravan to the site supply and / or check residual current circuit breaker.– Check water content, refill if required (close drain valve).– The electrical heating element is fitted with an excess temperature cut-out. In event of a fault, switch off at the control panel, wait 10 minutes, then switch on again.– Please contact the Truma Service.
Water supply		
Water drips from the safety/drain valve.	<ul style="list-style-type: none">– Water pressure too high.	<ul style="list-style-type: none">– Check water pressure (max. 2.8 bar), use a pressure reducer when connected to central water supply.
When opening the cold water tap, hot water tap comes out.	<ul style="list-style-type: none">– Hot water flows back through the cold water supply.	<ul style="list-style-type: none">– Fit a no-return valve in the cold water supply (refer to installation instructions "Water connection").

If this does not solve the problem, please contact the Truma Service.

Declaration of conformity

1. Information about the manufacturer

Name: Truma Gerätetechnik GmbH & Co. KG
Address: Wernher-von-Braun-Str. 12, D-85640 Putzbrunn

2. Device identification

Type / model

LPG-water heater / **Boiler Ultrastore Rapid GE (UGE 10)**

3. Meets the requirements of the following Directives

- 3.1 Gas Appliances Directive 90/396/EEC
- 3.2 Low Voltage Directive 2006/95/EC
- 3.3 Radio Interference in Vehicles 72/245/EEC
(with the supplements), UN ECE R10
- 3.4 Electromagnetic Compatibility 2004/108/EC
- 3.5 End-Of-Life Vehicle Directive 2000/53/EC
- 3.6 Drinking Water Directive 98/83/EC

and bears the type approval numbers
e1 03 2604, E1 10R-03 2604
and the CE symbol with the CE product ident. no.
CE-0085CL0489.

4. Basis of the conformity assessment

2004/104/EC, 2005/83/EC, EN 89, EN 15033, EN 298 (partly),
DIN EN 60335-1:2010,
IEC 60335-1:2001 mod. + A1:2004 + A2:2006,
DIN EN 60335-2-21:2009,
IEC 60335-2-21:2002 mod. + A1:2004 + A2:2008,
DIN 2001-2, DVGW W270, KTW.

EN 55014-1, CISPR 14-1,
EN 61000-3-2, IEC 61000-3-2,
EN 61000-3-3, IEC 61000-3-3,
ISO 7637 Part 2, ISO 7637 Part 3,
EN 55014-2, CISPR 14-2, EN 13611 Type B,
EN 61000-4-2:2009, IEC 61000-4-2,
EN 61000-4-3, IEC 61000-4-3, EN 61000-4-4, IEC 61000-4-4,
EN 61000-4-5, IEC 61000-4-5, EN 61000-4-6, IEC 61000-4-6,
EN 61000-4-8, IEC 61000-4-8

5. Auditing body

DVGW, Federal Motor Transport Authority

6. Information and the function of the signatory



Signature: Dr. Andreas Schmoll
Managing Director / Engineering

Putzbrunn, 10.01.2011

Manufacturer's terms of warranty

1. Case of warranty

The manufacturer grants a warranty for malfunctions in the appliance which are based on material or production faults. In addition to this, the statutory warranty claims against the seller remain valid.

A claim under warranty shall not pertain:

- for parts subject to wear and in cases of natural wear and tear,
- as a result of using components in the units that are not original Truma parts and using unsuitable gas pressure regulators,
- as a consequence of failure to respect Truma instructions for installation and use,
- as a consequence of improper handling,
- as a consequence of improper transport packing,
- use of water not compliant to Drinking Water Directive 98/83/EEC.

2. Scope of warranty

The warranty is valid for malfunctions as stated under item 1, which occur within 24 months after conclusion of the purchase agreement between the seller and the final consumer. The manufacturers will make good such defects by subsequent fulfilment, i.e. at their discretion either by repair or replacement. In the event of manufacturers providing service under warranty, the term of the warranty shall not recommence a new with regard to the repaired or replaced parts; rather, the old warranty period shall continue to run. More extensive claims, in particular claims for compensatory damages by purchasers or third parties, shall be excluded. This does not affect the rules of the product liability law.

The manufacturer shall bear the cost of employing the Truma customer service for the removal of a malfunction under warranty – in particular transportation costs, travelling expenses, job and material costs, as long as the service is carried out in Germany. Customer service carried out abroad is not covered by the warranty.

Additional costs based on complicated removal and installation conditions of the appliance (e.g. removal of furniture or parts of the vehicle body) do not come under warranty.

3. Raising the case of warranty

The manufacturer's address is:
Truma Gerätetechnik GmbH & Co. KG,
Wernher-von-Braun Strasse 12,
85640 Putzbrunn (Germany).

In Germany, always notify the Truma Service Centre if problems are encountered; in other countries the relevant service partners should be contacted (see Truma Service Booklet or www.truma.com). Any complaints are to be described in detail. Please also specify the device serial number and date of purchase.

In order for the manufacturers to be able to determine whether an incident subject to guarantee has occurred, the end user must, at his own risk, bring the device to the manufacturers or send it to them. If there is damage to heaters (heat exchangers), the gas pressure regulator must also be sent back to the factory.

In instances of the device being sent to the works, dispatch is to be effected by freight transport. In cases under guarantee, the works shall bear the transport costs or the costs of delivery and return. If the damage is deemed not to be a warranty case, the manufacturer shall notify the customer and shall specify repair costs which shall not be borne by the manufacturer; in this case, the customer shall also bear the shipping costs.

Installation instructions

Installation and repair are only to be carried out by an expert. Always read and follow the operating instructions carefully prior to starting any work!

⚠ Non-compliance with installation instructions or incorrect installation can result in endangerment of persons and property.

Intended use

This appliance has been designed for the installation in caravans, motor homes and other vehicles. It is not approved for installation in boats. Other forms of use are also possible following consultation with Truma.

Information regarding boats: For installation in boats Truma supplies the DVGW-tested boat water heater.

Regulations

Any modifications to the unit (including the exhaust duct and the cowl) or the use of spare parts and accessories that are important to the operation of the system (e.g. the time switch) that are not original Truma parts and failure to follow the installation and operating instructions will cancel the warranty and indemnify Truma from any liability claims. It also becomes illegal to use the appliance, and in some countries this even makes it illegal to use the vehicle.

In-vehicle installations must comply with the technical and administrative regulations of the respective country of use (e.g. EN 1949 for vehicles). The national regulations and rules must be complied with.

Water heater kit

The water heater kit contains

- 1 Assembled water heater
- 1 Cowl assembly with screws
- 1 Hot water connector
- 1 Cold water connector
- 1 Safety (pressure relief) drain valve
- 1 Wall switch (gas operation) with 3 m cable
- 1 Wall switch (230 V operation)
- 1 Installation template
- 1 Set literature
- 1 Label with warning information

In order to guarantee complete emptying of the water content, ongoing sealing tightness of the water connections and safety function **all enclosed parts must be used!**

Choice of location

Always install the appliance in such a way that it is easily accessible for service work at all times and can be easily removed and installed.

Locate the heater in such a way that the cowl can be mounted on the outside on a surface which is as straight and smooth as possible. This outside surface must be exposed to wind from all directions and, if possible, there should be no trim strips or covers in this area, mount heater on an appropriate base, if necessary.

The cowl may not be positioned within 500 mm (A) of a refuelling point or fuel tank breather outlet or within 300 mm (A) of a ventilator for the living space. If the cowl is positioned vertically below an opening part of a window, the water heater must be fitted with an automatic shut-off device (please refer to page 14) to prevent operation when the window is open.

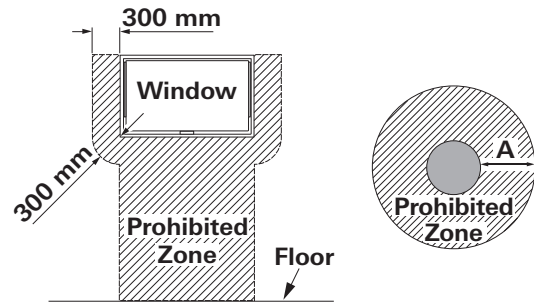

The heater must not be installed close to or directly behind a room / space heater.

To achieve reasonable air flow for electronics cooling, there should be a minimum distance of 20 mm between the electronics cover (34) and the walls of the furniture piece the Ultrastore is located in.

Installation of the water heater

Position template for cowl opening on the inside of the wall.

A = bottom edge of heater
B = lateral edge of heater

Drill 4 holes (C) with 10 mm dia. through the wall. Drill hole (E) with 15 mm dia. for condensation pipe (also possible from the outside = F).

Position template on the outside of the wall. The markings (C) must be above the through-holes. Saw cut-out section for cowl (D) 92 x 168 mm.

If the distance between outside wall and heater is more than 35 mm you must use the cowl extension VBO 2 (please refer to page 14) with an additional length of 50 mm. Saw out 100 x 176 mm along the dashed line.

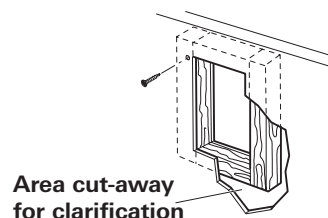

If there are any cavities in the area of the cowl, pack these with pieces of wood so as to be able to tighten the screws. The finished hole should be 168 mm high and 92 mm wide.

Cut out trim strips or such on the vehicle or place supports beneath them so as to make the cowl lie flat.

Place a support beneath the heater if the walls are sloping. An angle of inclination of 10 degrees is not to be exceeded.

Insert heater with cowl body (1) through the wall cut-out (2), allow approx. 5 mm to project out of the wall. Mount sealing frame (3) (the anti-twisting device ensures correct fitting!). Pre-drill holes for the 6 fastening bolts (4).

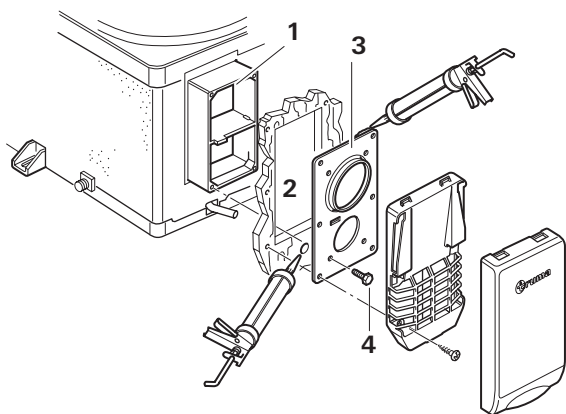

Remove sealing frame (3) and coat with non hardening mastic on the side facing the vehicle – do not use silicone!

! The sealing frame must be well sealed with respect to the front sides and the cross bars of the cowl body (1) as well as towards the outside wall!

Fasten sealing frame (3) to the cowl body using 4 self-cutting screws (4).

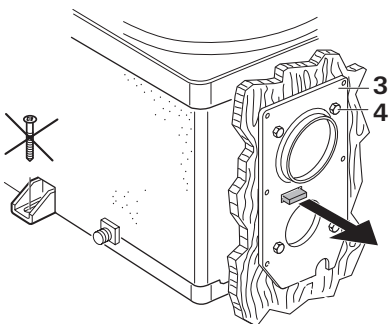

! Screw the sealing frame (3) in contact together with the cowl body (1) so the anti-twist device projects out!

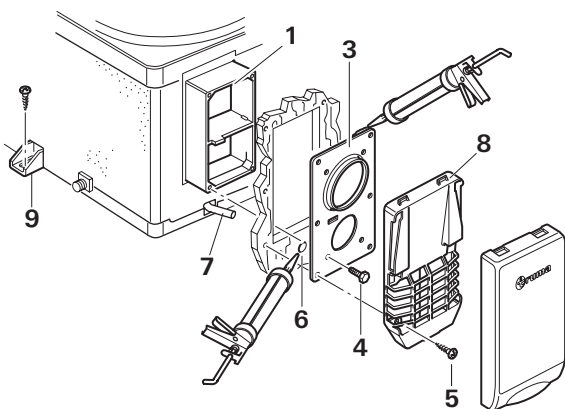

Seal the gap between the hole (6) and the condensation tube (7) with non hardening mastic – do not use silicone!

Mount the grille (8). Press the entire cowl assembly onto the vehicle wall and fasten with 6 screws (5).

Screw the water heater securely to the floor of the vehicle with at least two shackle plates (9) with the screws provided, B 5.5 x 25, on suitable base (plywood panel, laminated wood strips or metal base).

Water connection

All pressure and submersible waterpumps up to 2.8 bar and all mixed combination sets with or without an electrical switch, can be used for operating the water heater.

If connecting to a **central water supply** (rural or city connection) or when using more powerful pumps, a **pressure reducer** must be used which prevents pressures of greater than **2.8 bar** occurring in the system.

When using submersible pumps, a non-return valve (10 – not included in the scope of supply) must be fitted between the pump and the first branch point (arrow points in direction of flow).

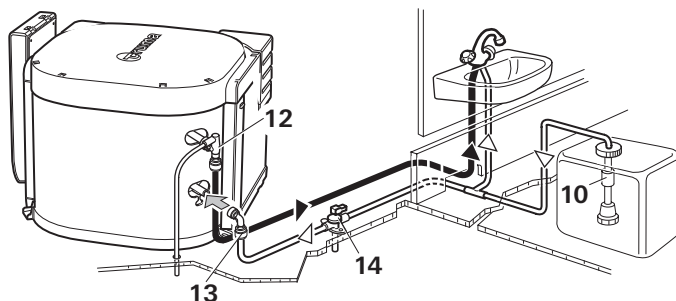

When using pressure pumps with high switching hysteresis, hot water may flow back through the cold water tap. To prevent the backflow, we recommend that a non-return valve (11 – not included in the scope of supply) be fitted between the outlet to the cold water tap and the drain valve.

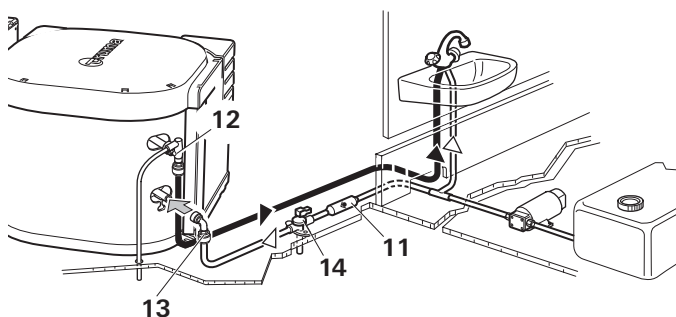

i When using the Truma Ultrastore together with the Truma Ultraflow pressure switch, the use of a non-return valve is essential (please refer to the pressure switch instruction).

! In order to guarantee complete emptying of the water content and ongoing sealing tightness of the water connections, the enclosed **water connectors** (12 + 13) and the **safety (pressure relief) drain valve** (14) **must be used!**

John Guest System rigid pipe routing

The water connectors (12 + 13) and safety/drain valve (14) supplied with the Truma Ultrastore have a 12 mm diameter fitting and are only approved to use with Original John Guest piping.

For connecting to rigid pipes with other diameters appropriate adapters (not included in scope of delivery) must be used.

Flexible water hose routing

As special accessories Truma supplies the water connectors (12 + 13) and safety/drain (14) valve with a 10 mm diameter hose nipple (please refer to page 14).

Pressure-resistant (up to 4.5 bar) and hot water-resistant water hoses in food quality with an internal diameter of 10 mm must be used.

! Route water hoses so that they are as short and free of kinks as possible. All hose connections must be secured using hose clamps (also for cold water)! Pressures of up to 4.5 bar can occur in the safety/drain valve (also with submergible pumps) because of the heat of the water and the resulting expansion.

All hot water hoses should be routed in a descending manner to the safety/drain valve! Otherwise no guarantee of protection from frost!

Installation of the safety (pressure relief) drain valve

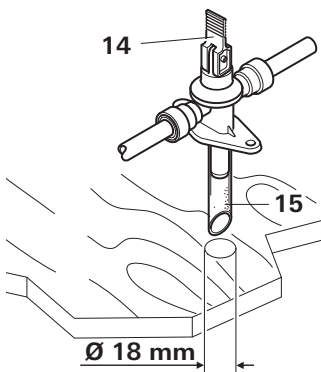

Install the safety/drain valve (14) at a place which is easily accessible, near the water heater. Drill hole with 18 mm diameter and pass through discharge socket with hose (15). Fasten safety/drain valve with 2 screws. The draining is to be directly to the outside at a position protected against splash water (apply splash guard, if necessary).

Water pipe routing

Connect cold water supply (16) to safety/drain valve (14). Direction of flow is unimportant.

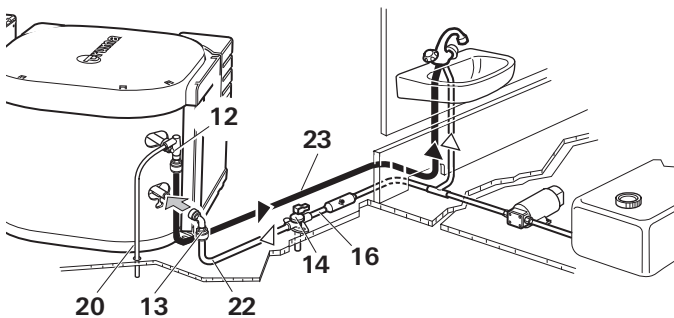

Slide elbow fitting (13) onto cold water connecting pipe (lower pipe) and elbow fitting with integrated ventilating valve (12) onto hot water connecting pipe (upper pipe) of water heater as far as it will go. Pull in opposite direction in order to make sure the elbow fittings are securely attached.

Push the venting hose, external diameter 11 mm (20), onto the hose grommet of the venting valve (21), and lay it to the outside without any kinks. Ensure that the bend radius is not smaller than 40 mm.

Cut off the ventilation hose approx. 20 mm below the floor of the vehicle at an angle of 45° to the direction of travel.

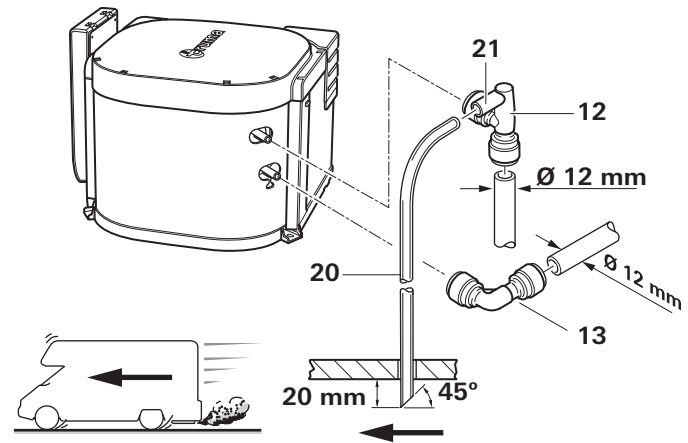

Produce connection (22) for cold water supply between safety/drain valve (14) and elbow (13 – lower pipe) on water heater.

Route the hot water pipe (23) from the elbow with integrated breather valve (12 – upper pipe) to the hot water consumers.

Gas connection

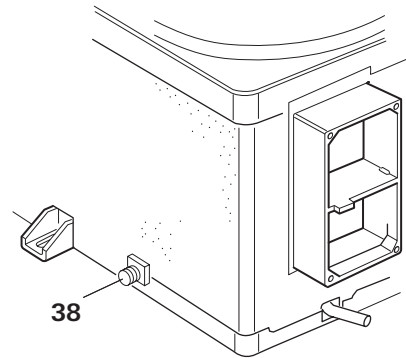

! The operating pressure for the gas supply is 30 mbar and must correspond to the operating pressure of the appliance (see name plate).

The 8 mm gas supply line is connected to the connection nozzle (38) with cutting ring connection. The cutting rings are to be selected according to the gas pipe used (for copper pipe: support sleeves and brass cutting ring as supplied). Carefully hold in place with a second wrench when tightening!

Before connecting to the water heater make sure that the gas lines are free from dirt, chips and such!

Route the pipes in such a way that the appliance can be removed again for servicing.

In areas frequented by people, keep the number of parting connections in the gas supply line to a technically feasible minimum.

The entire system must accord with the technical and administrative provisions of the individual country of use (e.g. EN 1949 for vehicles). National specifications and regulations must be respected.

Installation of the control panels

! When using control panels which are specific to the vehicle or the manufacturer, the electrical connection must be established in accordance with the Truma interface descriptions (refer to Electrical connection 230 V). Any modification made to the Truma components pertaining to this will lead to the invalidation of the guarantee, as well as to the exclusion of any claims for liability. The installer (manufacturer) is responsible for providing instructions for use for the user as well as for identification printing on the control panels.

When selecting the location, please bear the length of the connection cable of 3 m. If required, a cable extension of 5 m can be supplied (please refer to page 14).

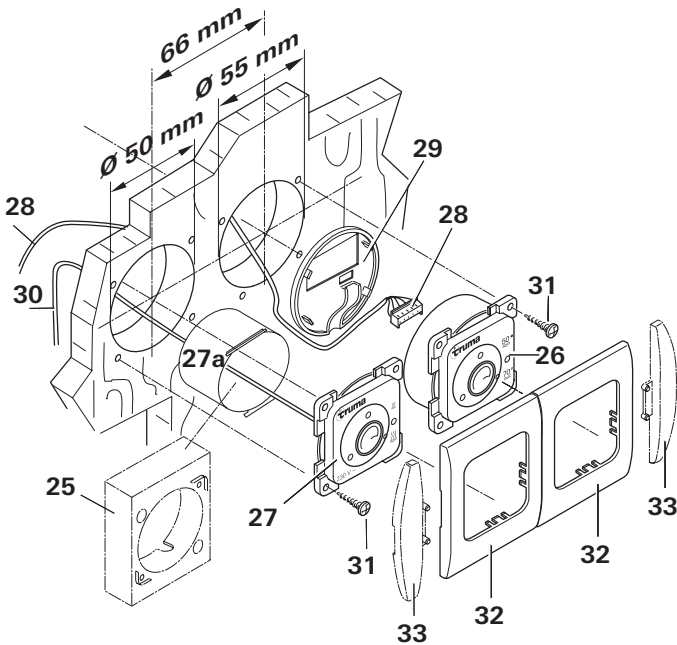

i If it is not possible to install the control panels flush with the surface, Truma can provide a surface-mounting frame (25) on request, as a special accessory (part no. 40000-52600).

The control panel for gas operation (26) and (if provided by Truma) the control panel for electrical operation (27) should be fitted next to one another if at all possible (distance between centres of holes 66 mm).

In each case, drill a hole with diameter 55 mm (gas operation) and 50 mm (electrical operation) – distance between centres of holes 66 mm –.

Plug the control panel cable (28) to the control panel for gas operation (26) and then fit on the rear cover cap (29) as a stress-relieving device.

Connect the control panel with a cable (30) 4 x 1.5 mm² (not in the scope of delivery – see “Connection 230 V control panel”). Feed the cable through the back cover (27a) and secure with the strain relief.

Push the cable through to the rear and lay the connection cables (28 + 30) to the water heater.

Lay the connection cable with the orange multipole connector (28) to the 12 V electronic control unit (for connection see “Electrical connection 12 V”).

Secure both control panels with 4 screws (31) each.

! On the 230 V control panel it must be ensured, that the rear cover locks correctly and fixed between the installation wall and the control panel frame. **The rear protection cover must not be removable when the control panel is mounted!**

Push on the front cover frame (32).

i To round off the appearance of the cover frame, Truma can provide side pieces (33) as special accessories in 8 different colours (please ask your dealer).

Electrical connection 12 V

Always disconnect the appliance from the power supply prior to working on electrical components. It is not sufficient to just switch off at the control panel!

The appliance must be disconnected from the vehicle main power supply when carrying out any electric welding work on the vehicle body.

! If the connections are transposed there is a risk of cable burning. This also rules out any guarantee or liability claims.

Unscrew cover (34) from the electronic control unit. Slide cable connector of control panel (28a) onto the p.c.b..

Put the cable (28) into the cable guide (28b) to fasten it securely.

The electrical connection 12 V is made at terminal (35).

orange = positive 12 V
blue = negative

To connect press with a small screwdriver from above and push in cable from the front.

Connect to fused vehicle mains (central electrical equipment 5 – 10 A) using a 2 x 1.5 mm² cable.

Negative cable to central earth. With lengths of over 6 m use a cable 2 x 2.5 mm². If connecting directly to the battery, the positive and negative cable must be fused. Screw cover (34) back on.

If necessary remove the outer cable mantle around the lead-through of the cover.

There are to be no other 12 V consuming appliances connected to the supply line!

The water heater fuse (36), 1.6 A, (slow-acting) is on the p.c.b..

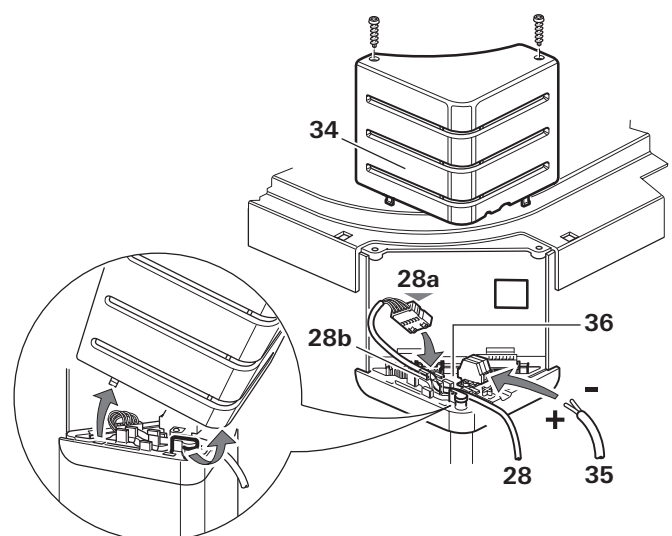

i When power packs or power supply units are being used, note that the output voltage is between 11 V and 15 V and the alternating current ripple is < 1.2 Vpp. We recommend the automatic chargers from Truma for the different applications. Please ask your dealer. Other chargers may be used only with a 12 V battery as a buffer.

Electrical connection 230 V

! The 230 V electrical connection must always be made by an expert (in accordance with VDE 0100, part 721 or IEC 60364-7-721, for example, in Germany). The information given here is not intended as instructions for you to carry out. It is for assisting the expert assigned to carry out the job, acting as auxiliary information when connecting the appliance!

The connection to the power supply is by means of a cable (e.g. flexible sheathed cable H05VV-F) to the 230 V supply line (3 x 1.5 mm²) and a cable to the 230 V control panel (4 x 1.5 mm²).

Always pay attention to connect carefully with the correct colours and numbers!

For maintenance and repair work a disconnecting device must be provided on the vehicle for all-pole disconnection from the power supply, with at least 3.5 mm contact clearance.

i All cables must be secured with cable clips. The cables from the heating element can be tightened to the support column on the side of the Ultrastore by means of clamping to the eye provided with a cable binder. Attaching water containers or pipes to the eye is not allowed.

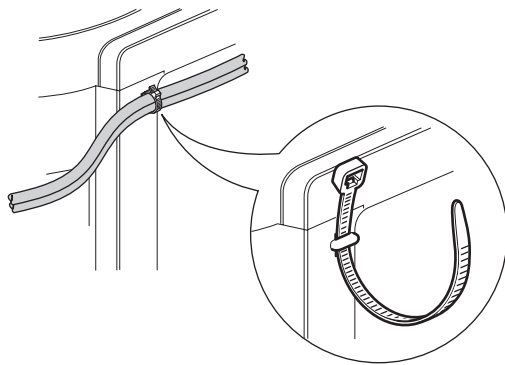

Connection 230 V control panel

Connect control panel cable, 230 V cable and heating element cable as shown in the drawing.

Cables must be in accordance with the technical rules and regulations of the country in which the vehicle is to be registered, for the first time.

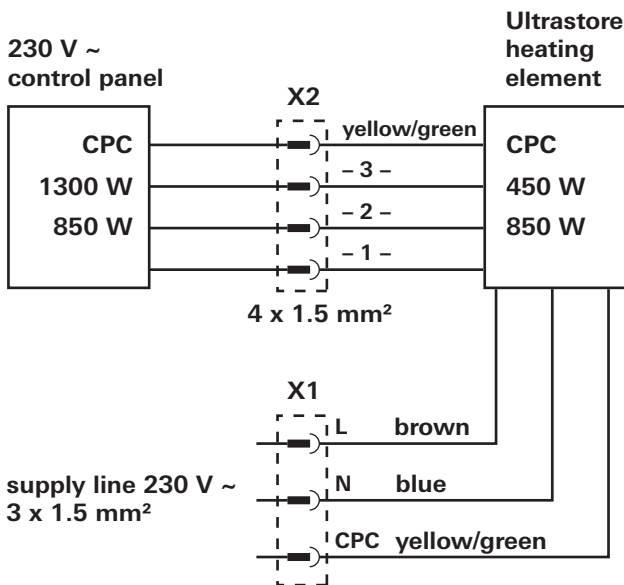

Correct connection of L and N line to the corresponding power supply lines must be ensured for safe operation.

Function check

After installation, the gas feed line must be tested for tightness by the pressure-drop method. A test certificate is to be issued.

Correct operation of 230 V heating elements must be checked by doing a power or current consumption measurement in switch position 850 W and 1300 W.

Position 850 W	3 – 4 A	750 – 900 W
Position 1300 W	5 – 6.5 A	1150 – 1400 W

If measured values are not within this range, please double check correct connection of the heating elements.

Then check all functions of the appliance, as specified in the operating instructions, in particular the water content draining function. **There shall be no claims under guarantee for damage caused by frost!**

Never operate the water heater without water contents. It is, however, possible to briefly check the electrical function without water contents. Always observe the operating instructions prior to operation!

The operating instructions and completed guarantee card are to be given to the owner of the vehicle.

Warning information

The installer or vehicle owner must apply the yellow sticker with the warning information, which is enclosed with the appliance, to a place in the vehicle where it is clearly visible to all users (e.g. on the wardrobe door)! Ask Truma to send you stickers, if necessary.

Accessories

Safety/drain valve and water connectors for flexible water hoses

- 34020-63900 Hot water connector, 10 mm
34020-16900 Cold water connector, 10 mm
70141-02 Safety/drain valve (4.5 bar), 10 mm



Cowl extension for wall thicknesses over 35 mm

- 70131-00 Cowl extension VBO 2



230 V Control panel for electrical operation

- 70020-35100 230 V Control panel



Control panel extension cable

- 70000-53500 Control extension 5 m



Shut-off device

To use when the cowl is fitted under a opening part of a window (only to use together with an appropriate window switch).

- 70020-00800 Shut-off device



Window switch

To use together with the shut-off device (universal fitting)

- 34000-85800 Window switch





In Germany, always notify the Truma Service Centre if problems are encountered; in other countries the relevant service partners should be contacted (see Truma Service Booklet or www.truma.com).

Having the equipment model and the serial number ready (see type plate) will speed up processing.

Service